

1. MECHANICAL DIMENSIONS :

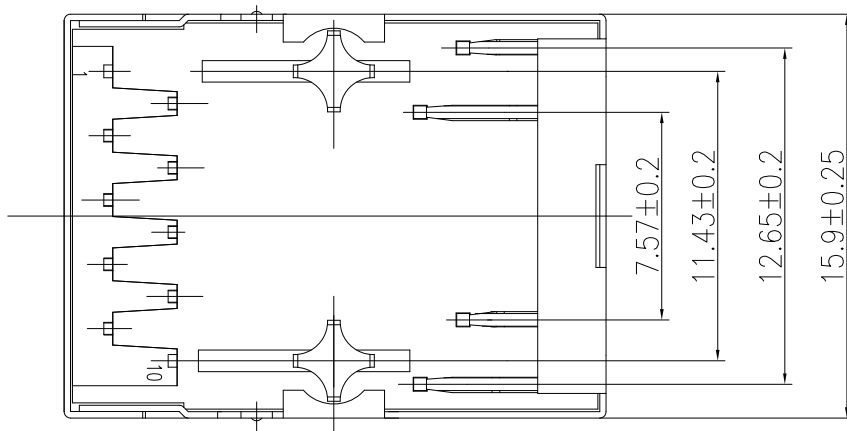
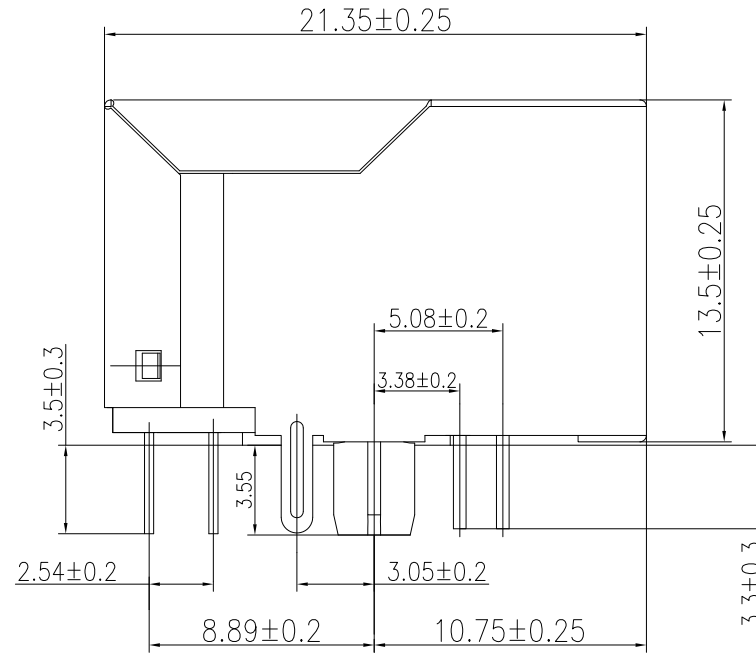
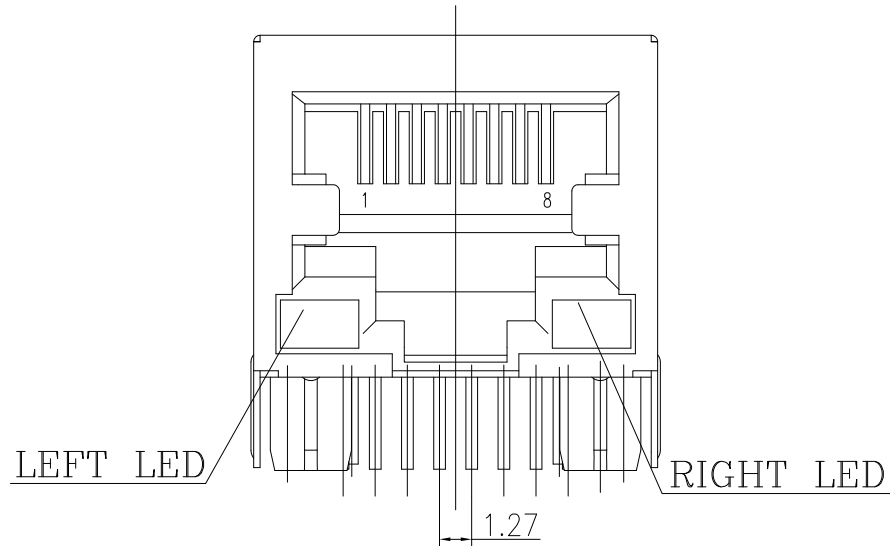

MATERIAL:

- 1.HOUSING: PA66+GLASS FILLED (UL 94V-0),BLACK
- 2.CONTACTS: 0.35mm THICKNESS PHOSPHOR BRONZE
ALLOY SELECTIVE GOLD PLATING OVER NICKEL
- 3.SHIELDING: 0.25mm THICKNESS COPPER ALLOY WITH TIN PLATED
- 4.GOLD PLATING: GOLD PLATING 3u" ON CONTACT AERA
- 5.JACK CAVITY CONFORMS TO FCC RULES AND REGULATIONS,PART 68 SUBPART F

REV.	ECN. NO.	DRAWN	DATE
A	NEW	JOHN	05/06/2015

DST-conn Tech. Co., Ltd.



⊗:QUALITY CONTROL ITEM		GENERAL TOLERANCE		PART NO.: 11BDWD-xxxx-xxx		
APPROVED		.X± 0.38	X.'± 2'	TITLE:RJ45 1X1 W/LED,SHELL		
CHECKED		.XX± 0.25	.X'± 1'	100/1000 MBPS 10P8C DOWN		
DRAWN		.XXX± 0.13		UNIT: mm	SCALE: 1:1	SHEET: 1/4
						REV.: A

説明: △ :備註 ◇ :版本變更 ④ :尺寸序號 ■ :重點尺寸 ▼ :CPK尺寸

SIZE: A4

2. PCB LAYOUT :

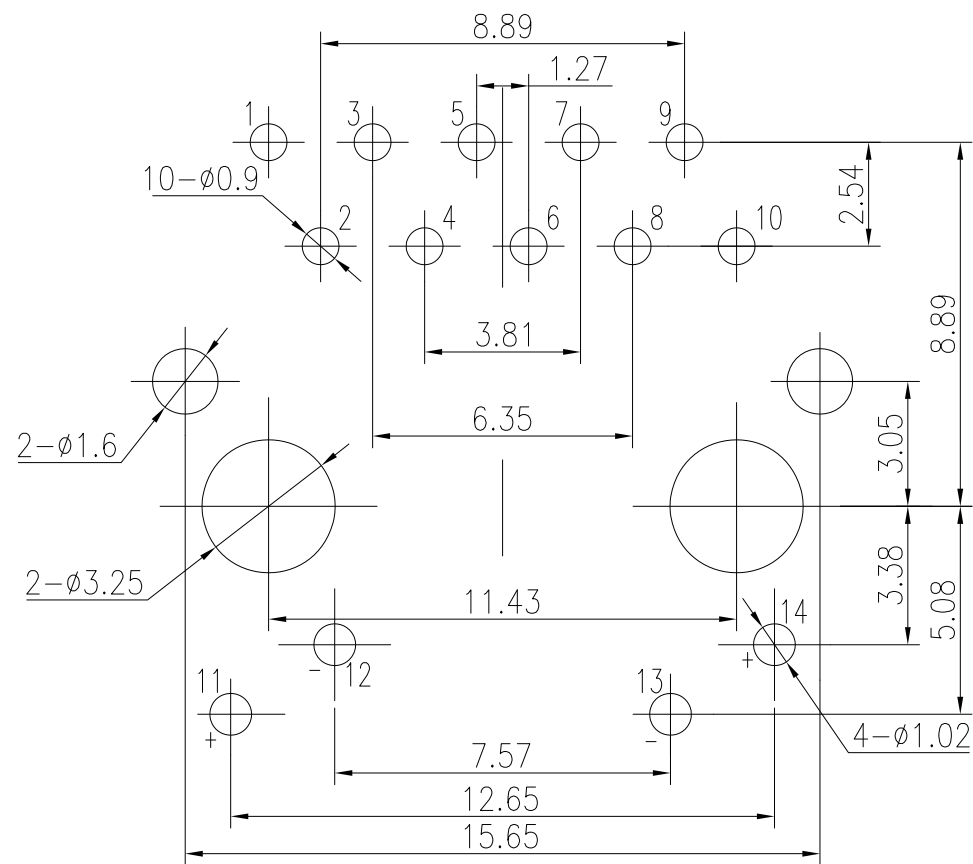

SUGGESTED PCB LAYOUT
(TOP VIEW)
DIMENSIONAL TOLERANCE: .XX ±0.05[0.002]

3. LED SCHEMATIC :

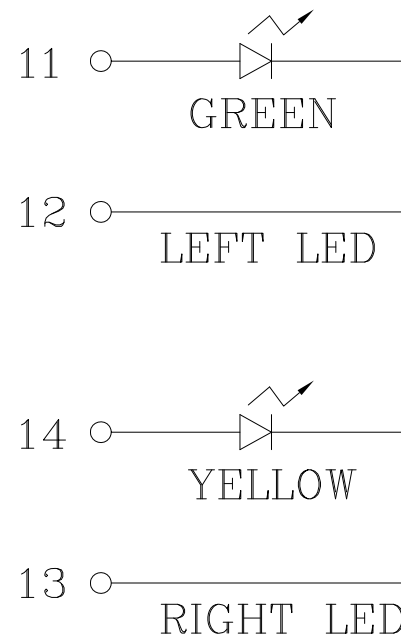

REV.	ECN. NO.	DRAWN	DATE
A	NEW	JOHN	05/06/2015

DST-conn Tech. Co., Ltd.

HSE

Compliant

⊗:QUALITY CONTROL ITEM		GENERAL TOLERANCE	PART NO.:
APPROVED		.X± 0.38 X.*± 2'	11BDWD-xxxx-xxx
CHECKED		.XX± 0.25 .X.*± 1'	TITLE:RJ45 1X1 W/LED,SHELL
DRAWN		.XXX± 0.13	100/1000 MBPS 10P8C DOWN
		UNIT: mm	SCALE: 1:1
			SHEET: 2/4
			REV.: A

說明: △ :備註 ◇ :版本變更 ④ :尺寸序號 ■ :重點尺寸 ▼ :CPK尺寸

SIZE: A4

4. SCHEMATIC :

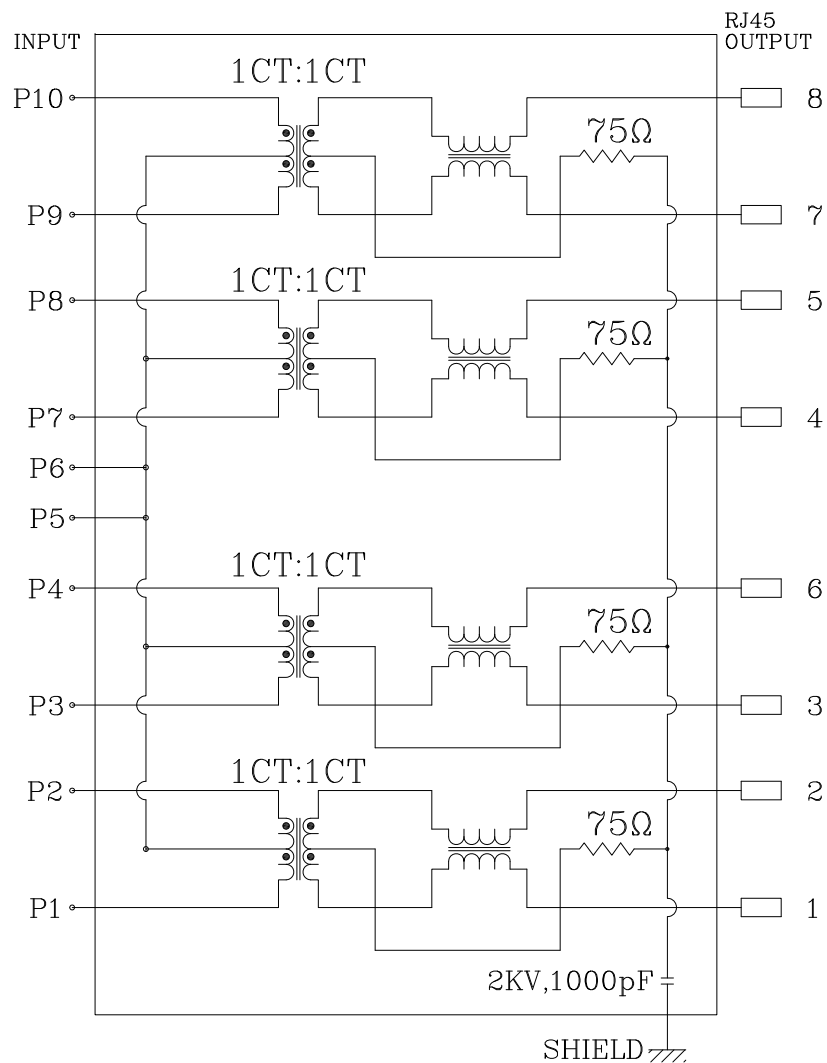

5. ELECTRICAL CHARACTERISTICS :

ELECTRICAL SPECIFICATIONS:

TEST NOTES:(25°±5°C)

1. TR:(100KHz,0.1V); 100%
 PINS:(P1,P2):(J1,J2)=1:1±3%;(P3,P4):(J3,J6)=1:1±3%
 PINS:(P7,P8):(J4,J5)=1:1±3%;(P9,P10):(J7,J8)=1:1±3%
2. LX:(100KHz,100mV,8mA, DC Bias) 100%
 PINS:(P1,P2),(P3,P4),(P7,P8),(P9,P10)=350uH MINIMUM
3. DCR: 100%
 PINS:(J1,J2),(J3,J6),(J4,J5),(J7,J8)=1.2 OHM MAXIMUM
4. HIPOT: 100%
 PINS(P1,P2)TO(J1,J2),(P3,P4)TO(J3,J6)=1500VAC FOR 60 SECONDS
 PINS(P7,P8)TO(J4,J5),(P9,P10)TO(J7,J8)=1500VAC FOR 60 SECONDS
5. INSERTION LOSS:
 -1.0dB MAXIMUM AT 1MHz TO 100MHz;
- 6.RETURN LOSS:
 -18dB MINIMUM AT 1MHz TO 30MHz;
 -16dB MINIMUM AT 30MHz TO 60MHz;
 -12dB MINIMUM AT 60MHz TO 100MHz;
- 7.CROSS TALK:
 -30dB MINIMUM AT 1MHz TO 100MHz
- 8.COMMON TO COMMON MODE REJECTION:
 -30dB MINIMUM AT 1MHz TO 100MHz

REV.	ECN. NO.	DRAWN	DATE
A	NEW	JOHN	05/06/2015

DST-conn Tech. Co., Ltd.

HSE

Compliant

⊗:QUALITY CONTROL ITEM		GENERAL TOLERANCE		PART NO.: 11BDWD-xxxx-xxx	
APPROVED		.X± 0.38	X.'± 2'	TITLE:RJ45 1X1 W/LED,SHELL	
CHECKED		.XX± 0.25	.X'± 1'	100/1000 MBPS 10P8C DOWN	
DRAWN		.XXX± 0.13		SCALE: 1:1	SHEET: 3/4
		UNIT: mm			REV.: A

説明: △ :備註 ◇ :版本變更 ④ :尺寸序號 ■ :重點尺寸 ▼ :CPK尺寸

SIZE: A4

1 2 3 4 5 6 7 8

F

E

D

C

B

A

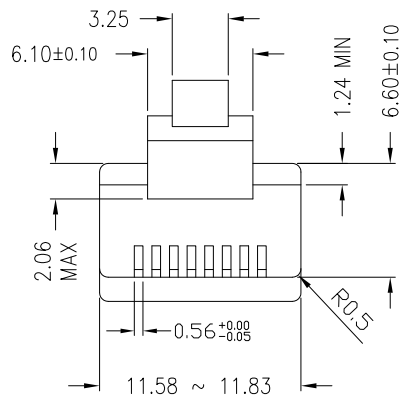

* There must be no damage to housing or locking latch. There must be no nicks or cuts in cable.
 * Durability : 750 cycles generally

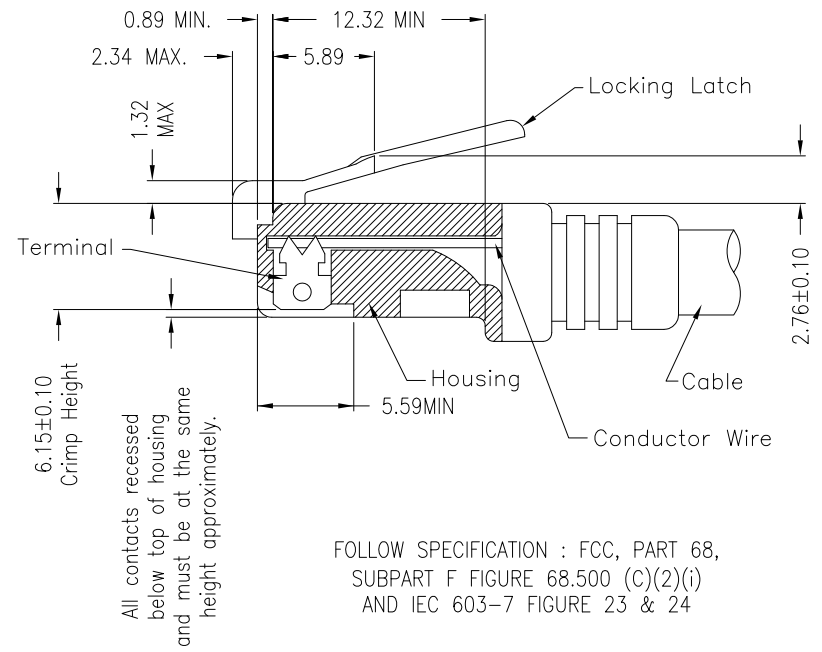

FOLLOW SPECIFICATION : FCC, PART 68, SUBPART F FIGURE 68.500 (C)(2)(i) AND IEC 603-7 FIGURE 23 & 24

STANDARD MODULAR PLUG ASSEMBLY

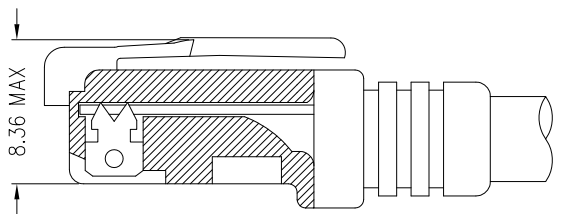

FOLLOW SPECIFICATION : FCC, PART 68, SUBPART F FIGURE 68.500 (C)(2)(ii)

REV.	ECN. NO.	DRAWN	DATE
A	NEW	JOHN	05/06/2015

DST-conn Tech. Co., Ltd.



⊗:QUALITY CONTROL ITEM		GENERAL TOLERANCE .X± 0.38 X.*± 2' .XX± 0.25 .X.*± 1' .XXX± 0.13		PART NO.: 11BDWD-xxxx-xxx	
APPROVED		UNIT: mm		TITLE:RJ45 1X1 W/LED,SHELL 100/1000 MBPS 10P8C DOWN	
CHECKED		SCALE: 1:1		SHEET: 4/4	REV.: A
DRAWN					

説明: △ :備註 ◇ :版本變更 ④ :尺寸序號 ■ :重點尺寸 ▼ :CPK尺寸

1 2 3

F

E

D

C

B

SIZE: A4