

1. MECHANICAL DIMENSIONS :

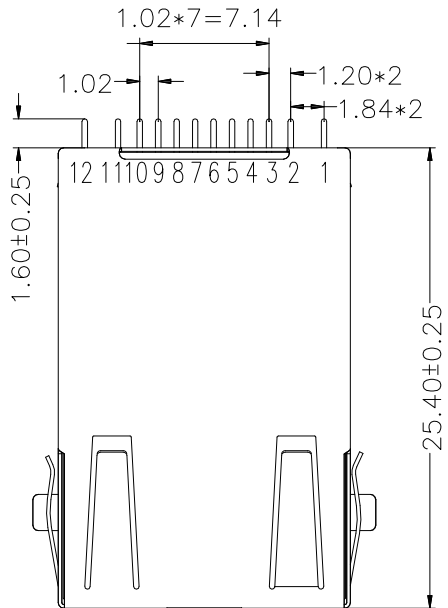
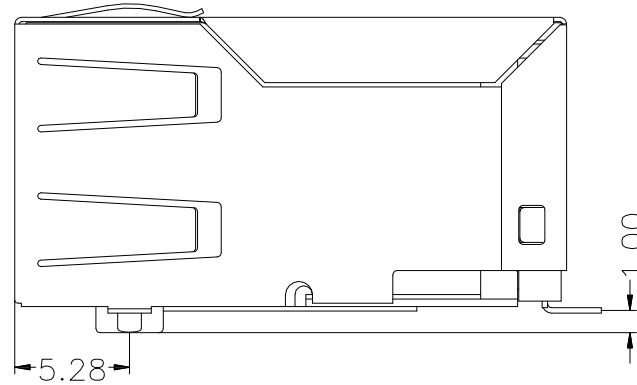
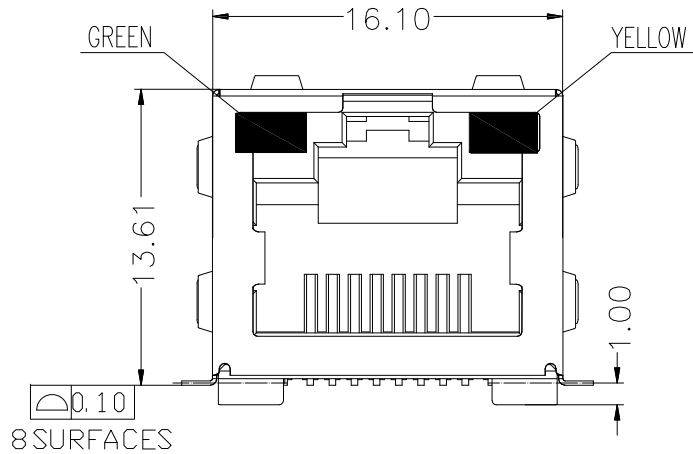

MATERIAL:

1. HOUSING: PA9T+GLASS FILLED (UL 94V-0), BLACK
2. CONTACTS: 0.40mm THICKNESS PHOSPHOR BRONZE
ALLOY SELECTIVE GOLD PLATING OVER NICKEL
3. SHIELDING: 0.25mm THICKNESS COPPER ALLOY WITH TIN PLATED
4. GOLD PLATING: GOLD PLATING 6u" ON CONTACT AREA
5. JACK CAVITY CONFORMS TO FCC RULES AND REGULATIONS, PART 68 SUBPART FΩ

REV.	ECN. NO.	DRAWN	DATE
A	NEW	JOHN	29/10/2014

DST-conn Tech. Co., Ltd.

HISF

Compliant

⊗:QUALITY CONTROL ITEM		GENERAL TOLERANCE		PART NO.: 11BSAS-xxxx-xxx			
APPROVED		.X± 0.38	X.'± 2'	TITLE:RJ45 1X1 TAB UP SMT TYPE 10/100 MBPS FILTER 8P8C			
CHECKED		.XX± 0.25	.X'± 1'				
DRAWN		.XXX± 0.13		UNIT: mm	SCALE: 1:1	SHEET: 1/4	REV.: A

說明: △ :備註 ◇ :版本變更 ④ :尺寸序號 ■ :重點尺寸 ▼ :CPK尺寸

SIZE: A4

2. PCB LAYOUT :

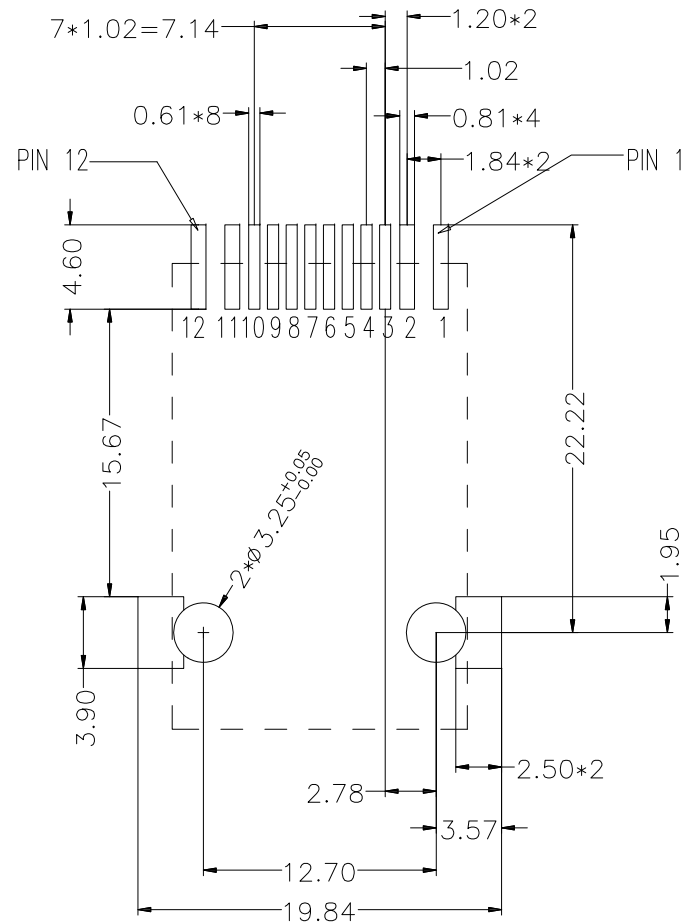

SUGGESTED PCB LAYOUT

(TOP VIEW)

DIMENSIONAL TOLERANCE: .XX ±0.05[0.002]

3. LED SCHEMATIC :

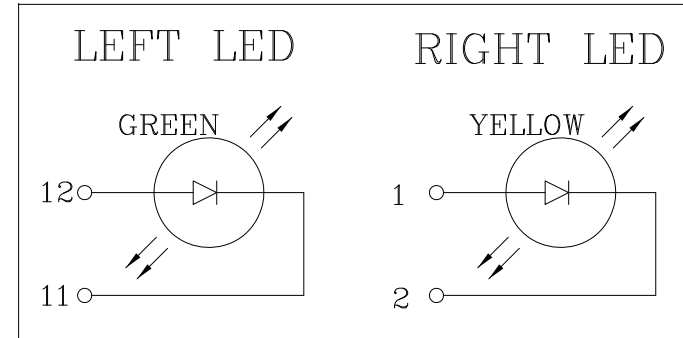

REV.	ECN. NO.	DRAWN	DATE
A	NEW	JOHN	29/10/2014

⊗:QUALITY CONTROL ITEM		GENERAL TOLERANCE	PART NO.:
APPROVED		.X± 0.38 X.'± 2'	11BSAS-xxxx-xxx
CHECKED		.XX± 0.25 .X'± 1"	TITLE:RJ45 1X1 TAB UP SMT TYPE
DRAWN		.XXX± 0.13	10/100 MBPS FILTER 8P8C
		UNIT: mm	SCALE: 1:1
			SHEET: 2/4
			REV.: A

DST-conn Tech. Co., Ltd.

HISF

Compliant

説明: △ :備註 ◇ :版本變更 ④ :尺寸序號 ■ :重點尺寸 ▼ :CPK尺寸

SIZE: A4

4. SCHEMATIC :

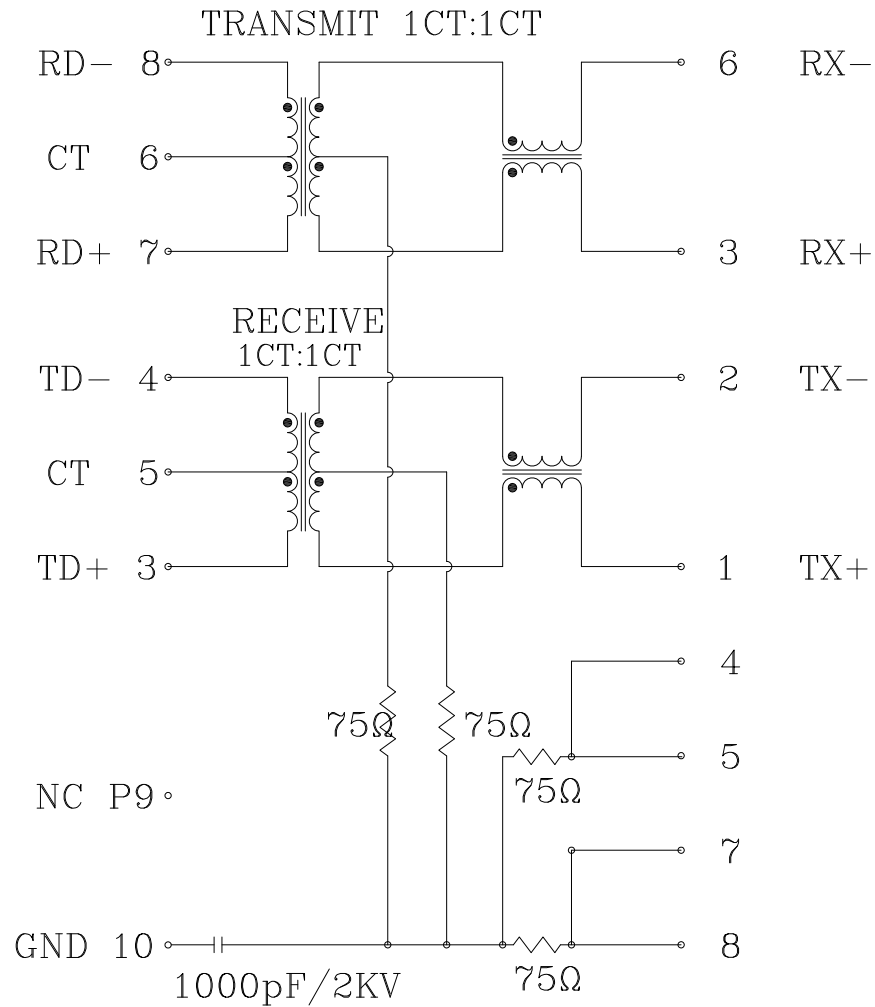

5. ELECTRICAL CHARACTERISTICS :

ELECTRICAL SPECIFICATIONS:

TEST NOTES:(25°±5°C)

1. TR:(100KHz,0.1V); 100%

PINS:(P3,P4):(J1,J2)=1:1±3%;(P7,P8):(J3,J6)=1:1±3%

2. LX:(100KHz,100mV,8mA, DC Bias) 100%

PINS: (P3,P4),(P7,P8)=350uH MINIMUM

3. DCR: 100%

PINS:(J1,J2),(J3,J6),(J4,J5),(J7,J8)=1.2 OHM MAXIMUM

4. HIPOT: 100%

PINS(P3,P4)TO(J1,J2),(P7,P8)TO(J3,J6)=1500VAC FOR 60 SECONDS

5. INSERTION LOSS:

-1.0dB MAXIMUM AT 1MHz TO 100MHz;

6.RETURN LOSS:

-18dB MINIMUM AT 1MHz TO 30MHz;

-16dB MINIMUM AT 30MHz TO 60MHz;

-12dB MINIMUM AT 60MHz TO 100MHz;

7.CROSS TALK:

-30dB MINIMUM AT 1MHz TO 100MHz

8.COMMON TO COMMON MODE REJECTION:

-30dB MINIMUM AT 1MHz TO 100MHz

REV.	ECN. NO.	DRAWN	DATE
A	NEW	JOHN	29/10/2014

DST-conn Tech. Co., Ltd.

HISF

Compliant

⊗:QUALITY CONTROL ITEM		GENERAL TOLERANCE	PART NO.: 11BSAS-xxxx-xxx	
APPROVED		.X± 0.38 X.'± 2'	TITLE:RJ45 1X1 TAB UP SMT TYPE 10/100 MBPS FILTER 8P8C	
CHECKED		.XX± 0.25 .X'± 1'		
DRAWN		.XXX± 0.13		
UNIT: mm		SCALE: 1:1	SHEET: 3/4	REV.: A

說明: △ :備註 ◇ :版本變更 ⑨ :尺寸序號 ■ :重點尺寸 ▼ :CPK尺寸

SIZE: A4

1 2 3 4 5 6 7 8

F

E

D

C

B

A

F

E

D

C

B

SIZE: A4

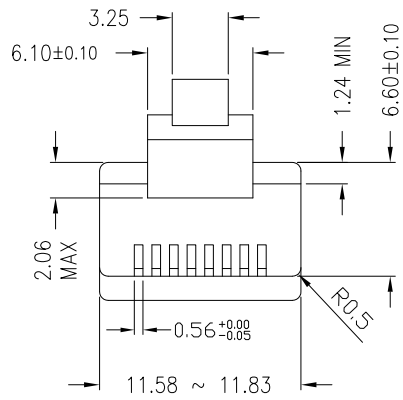

* There must be no damage to housing or locking latch. There must be no nicks or cuts in cable.
 * Durability : 750 cycles generally

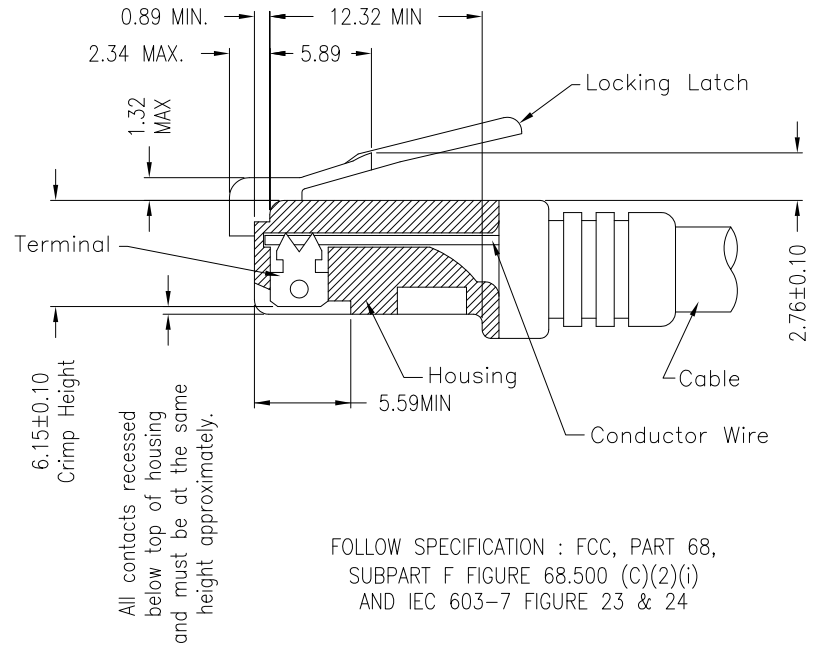

FOLLOW SPECIFICATION : FCC, PART 68, SUBPART F FIGURE 68.500 (C)(2)(i) AND IEC 603-7 FIGURE 23 & 24

STANDARD MODULAR PLUG ASSEMBLY

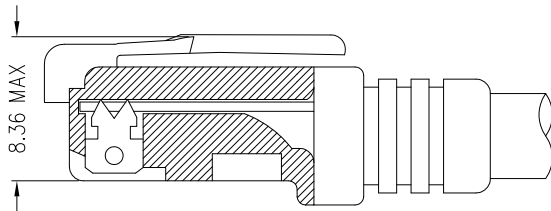

FOLLOW SPECIFICATION : FCC, PART 68, SUBPART F FIGURE 68.500 (C)(2)(ii)

REV.	ECN. NO.	DRAWN	DATE
A	NEW	JOHN	29/10/2014

DST-conn Tech. Co., Ltd.

HISF

Compliant

⊗:QUALITY CONTROL ITEM		GENERAL TOLERANCE		PART NO.: 11BSAS-xxxx-xxx		
APPROVED		.X± 0.38	X.*± 2'	TITLE:RJ45 1X1 TAB UP SMT TYPE		
CHECKED		.XX± 0.25	.X.*± 1'	10/100 MBPS FILTER 8P8C		
DRAWN		.XXX± 0.13		UNIT: mm	SCALE: 1:1	SHEET: 4/4
						REV.: A

1 2 3 说明: △ :備註 ◇ :版本變更 ④ :尺寸序號 ■ :重點尺寸 ▼ :CPK尺寸