

1. MECHANICAL DIMENSIONS :

LEFT LED1 17.21±0.35 RIGHT LED2

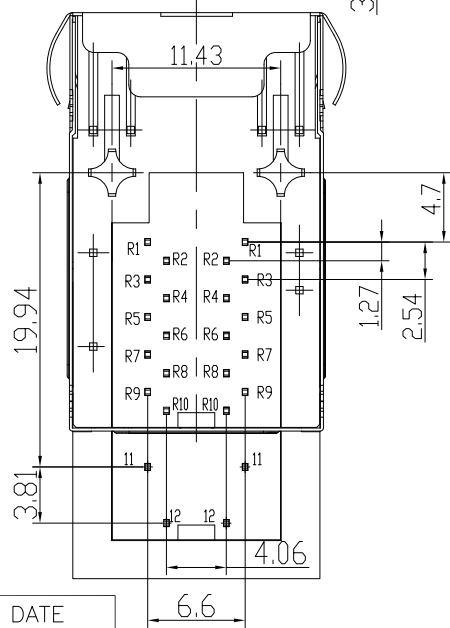
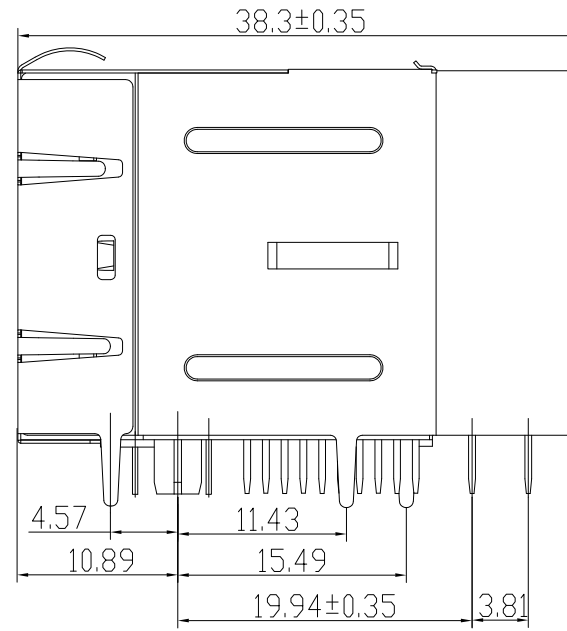
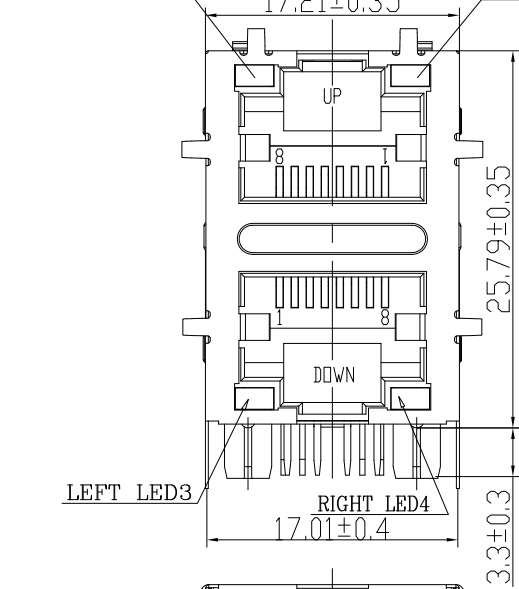

MATERIAL:

- 1.HOUSING: PA66+GLASS FILLED (UL 94V-0),BLACK
- 2.CONTACTS: 0.46mm THICKNESS PHOSPHOR BRONZE
ALLOY SELECTIVE GOLD PLATING OVER NICKEL
- 3.SHIELDING: 0.2mm THICKNESS COPPER ALLOY WITH TIN PLATED
- 4.GOLD PLATING: GOLD PLATING 6u" ON CONTACT AERA
- 5.JACK CAVITY CONFORMS TO FCC RULES AND REGULATIONS,PART 68 SUBPART F
- 6.POE RATING:16W,350mA,48V,FOR IEEE802.3AF REEQUIREMENT

REV.	ECN. NO.	DRAWN	DATE
A	NEW	JOHN	09/09/15

DST-conn Tech. Co., Ltd.

HSF

Compliant

⊗:QUALITY CONTROL ITEM		GENERAL TOLERANCE		PART NO.: 21BP2D-xxxx-xxx		
APPROVED		.X± 0.38	X.'± 2'	TITLE:RJ45 2X1 W/ LED,SHELL,T/S 100/1000 FILTER 10P8C POE		
CHECKED		.XX± 0.25	.X'± 1'			
DRAWN		.XXX± 0.13				
UNIT: mm		SCALE: 1:1	SHEET: 1/4	REV.: A		

説明: △ :備註 ◇ :版本變更 ④ :尺寸序號 ■ :重點尺寸 ▼ :CPK尺寸

SIZE: A4

2. PCB LAYOUT :

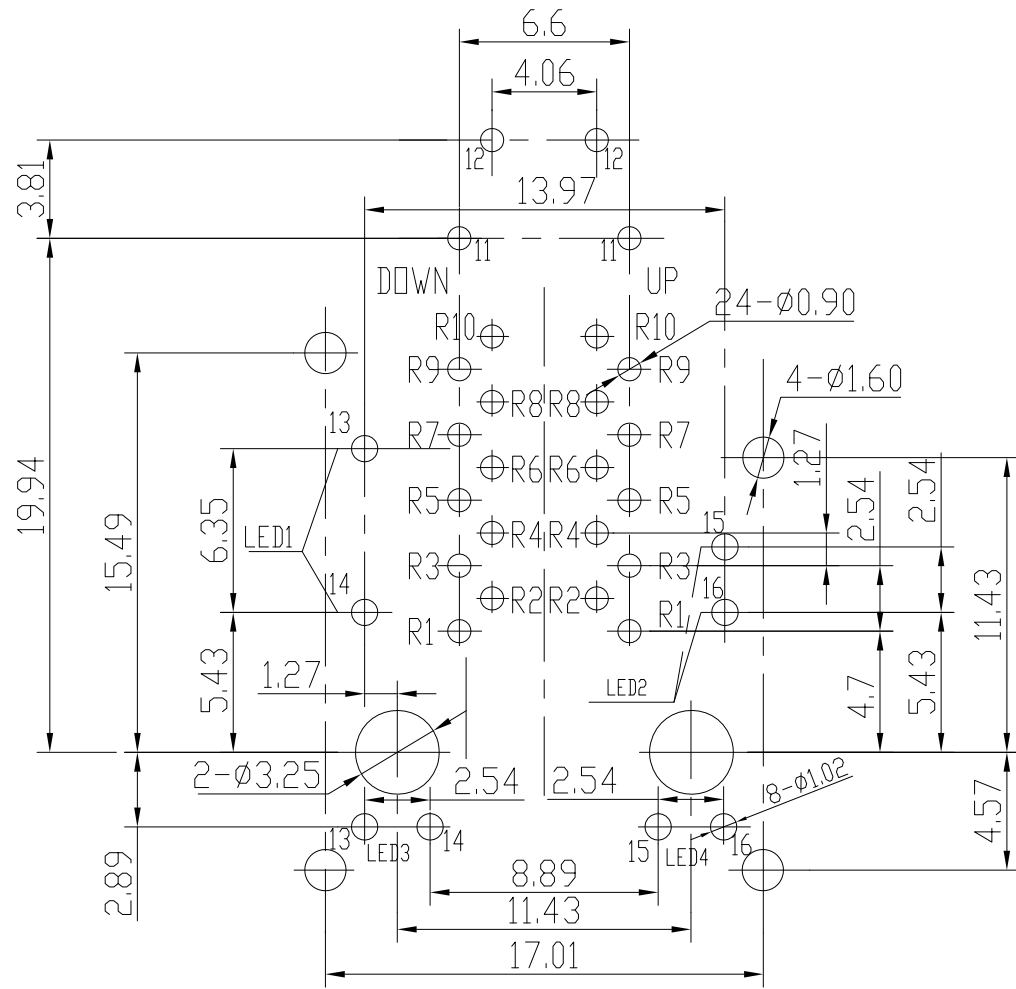

SUGGESTED PCB LAYOUT

(TOP VIEW)

DIMENSIONAL TOLERANCE: .XX ±0.05[0.002]

3. LED SCHEMATIC :

LEFT LED 1&3

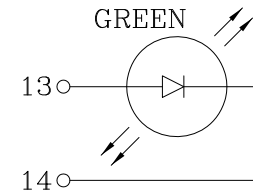

RIGHT LED 2&4

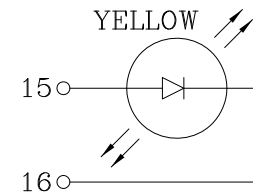

REV.	ECN. NO.	DRAWN	DATE
A	NEW	JOHN	09/09/15

⊗:QUALITY CONTROL ITEM		GENERAL TOLERANCE	PART NO.: 21BP2D-xxxx-xxx
APPROVED		.X± 0.38 X:± 2'	TITLE:RJ45 2X1 W/ LED,SHELL,T/S
CHECKED		.XX± 0.25 .X:± 1'	100/1000 FILTER 10P8C POE
DRAWN		.XXX± 0.13	SCALE: 1:1 SHEET: 2/4 REV.: A
UNIT: mm			

DST-conn Tech. Co., Ltd.



說明: △ :備註 ◇ :版本變更 ① :尺寸序號 ■ :重點尺寸 ▼ :CPK尺寸

SIZE: A4

4. SCHEMATIC :

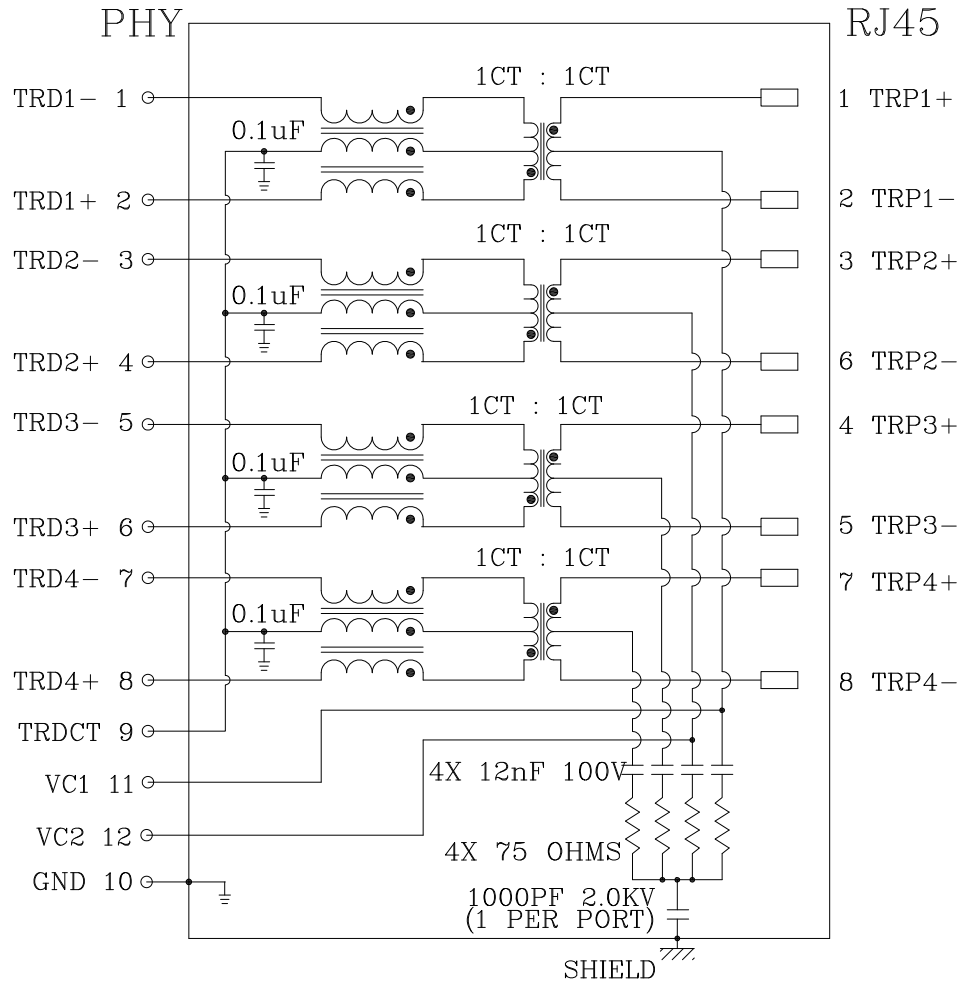

5. ELECTRICAL CHARACTERISTICS :

ELECTRICAL SPECIFICATIONS:

TEST NOTES:(25°±5°C)

1. TR:(100KHz,0.1V); 100%

PINS:(P1,P2):(J1,J2)=1:1±3%;(P3,P4):(J3,J6)=1:1±3%

PINS:(P5,P6):(J4,J5)=1:1±3%;(P7,P8):(J7,J8)=1:1±3%

2. LX:(100KHz,100mV,8mA, DC Bias) 100%

PINS:(P1,P2),(P3,P4),(P5,P6),(P7,P8)=350uH MINIMUM

3. DCR: 100%

PINS:(J1,J2),(J3,J6),(J4,J5),(J7,J8)=1.2 OHM MAXIMUM

4. HIPOT: 100%

PINS(P1,P2)TO(J1,J2),(P3,P4)TO(J3,J6)=1500VAC FOR 60 SECONDS

PINS(P5,P6)TO(J4,J5),(P7,P8)TO(J7,J8)=1500VAC FOR 60 SECONDS

5. INSERTION LOSS:

-1.0dB MAXIMUM AT 1MHz TO 100MHz;

6.RETURN LOSS:

-18dB MINIMUM AT 1MHz TO 30MHz;

-16dB MINIMUM AT 30MHz TO 60MHz;

-12dB MINIMUM AT 60MHz TO 100MHz;

7.CROSS TALK:

-30dB MINIMUM AT 1MHz TO 100MHz

8.COMMON TO COMMON MODE REJECTION:

-30dB MINIMUM AT 1MHz TO 100MHz

REV.	ECN. NO.	DRAWN	DATE
A	NEW	JOHN	09/09/15

DST-conn Tech. Co., Ltd.



⊗:QUALITY CONTROL ITEM		GENERAL TOLERANCE		PART NO.: 21BP2D-xxxx-xxx		
APPROVED		.X± 0.38	X.*± 2'	TITLE:RJ45 2X1 W/ LED,SHELL,T/S		
CHECKED		.XX± 0.25	.X'± 1'	100/1000 FILTER 10P8C POE		
DRAWN		.XXX± 0.13		UNIT: mm	SCALE: 1:1	SHEET: 3/4
						REV.: A

説明: △ :備註 ◇ :版本變更 ⑨ :尺寸序號 ■ :重點尺寸 ▼ :CPK尺寸

SIZE: A4

1 2 3 4 5 6 7 8

F

E

D

C

B

A

F

E

D

C

B

SIZE: A4

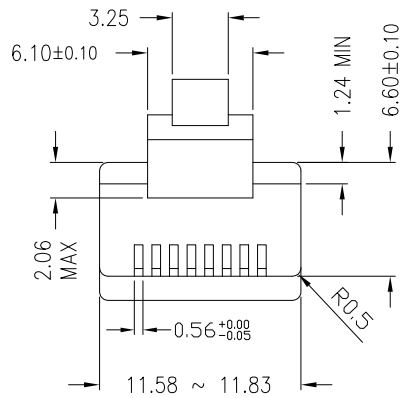

* There must be no damage to housing or locking latch. There must be no nicks or cuts in cable.
 * Durability : 750 cycles generally

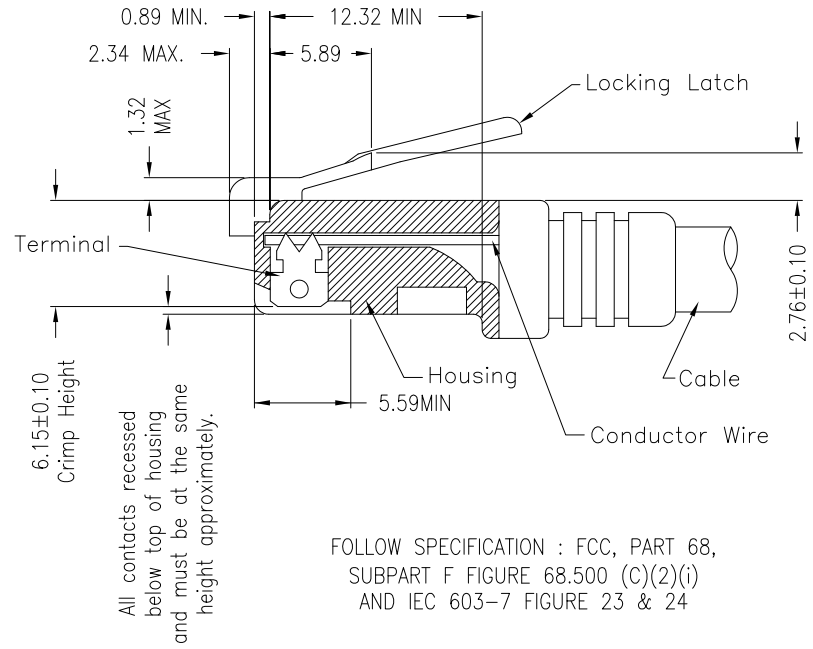

FOLLOW SPECIFICATION : FCC, PART 68, SUBPART F FIGURE 68.500 (C)(2)(i) AND IEC 603-7 FIGURE 23 & 24

STANDARD MODULAR PLUG ASSEMBLY

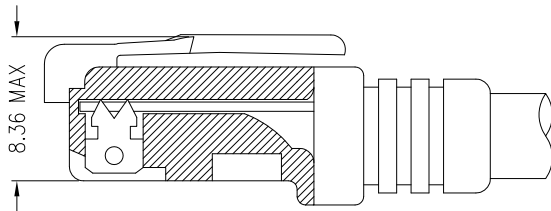

FOLLOW SPECIFICATION : FCC, PART 68, SUBPART F FIGURE 68.500 (C)(2)(ii)

REV.	ECN. NO.	DRAWN	DATE
A	NEW	JOHN	09/09/15

DST-conn Tech. Co., Ltd.



⊗:QUALITY CONTROL ITEM		GENERAL TOLERANCE .X± 0.38 X:± 2' .XX± 0.25 .X:± 1' .XXX± 0.13		PART NO.: 21BP2D-xxxx-xxx		
APPROVED				TITLE:RJ45 2X1 W/ LED,SHELL,T/S		
CHECKED				100/1000 FILTER 10P8C POE		
DRAWN		UNIT: mm		SCALE: 1:1	SHEET: 4/4	REV.: A

説明: △ :備註 ◇ :版本變更 ① :尺寸序號 ■ :重點尺寸 ▼ :CPK尺寸

1 2 3