

1. MECHANICAL DIMENSIONS :

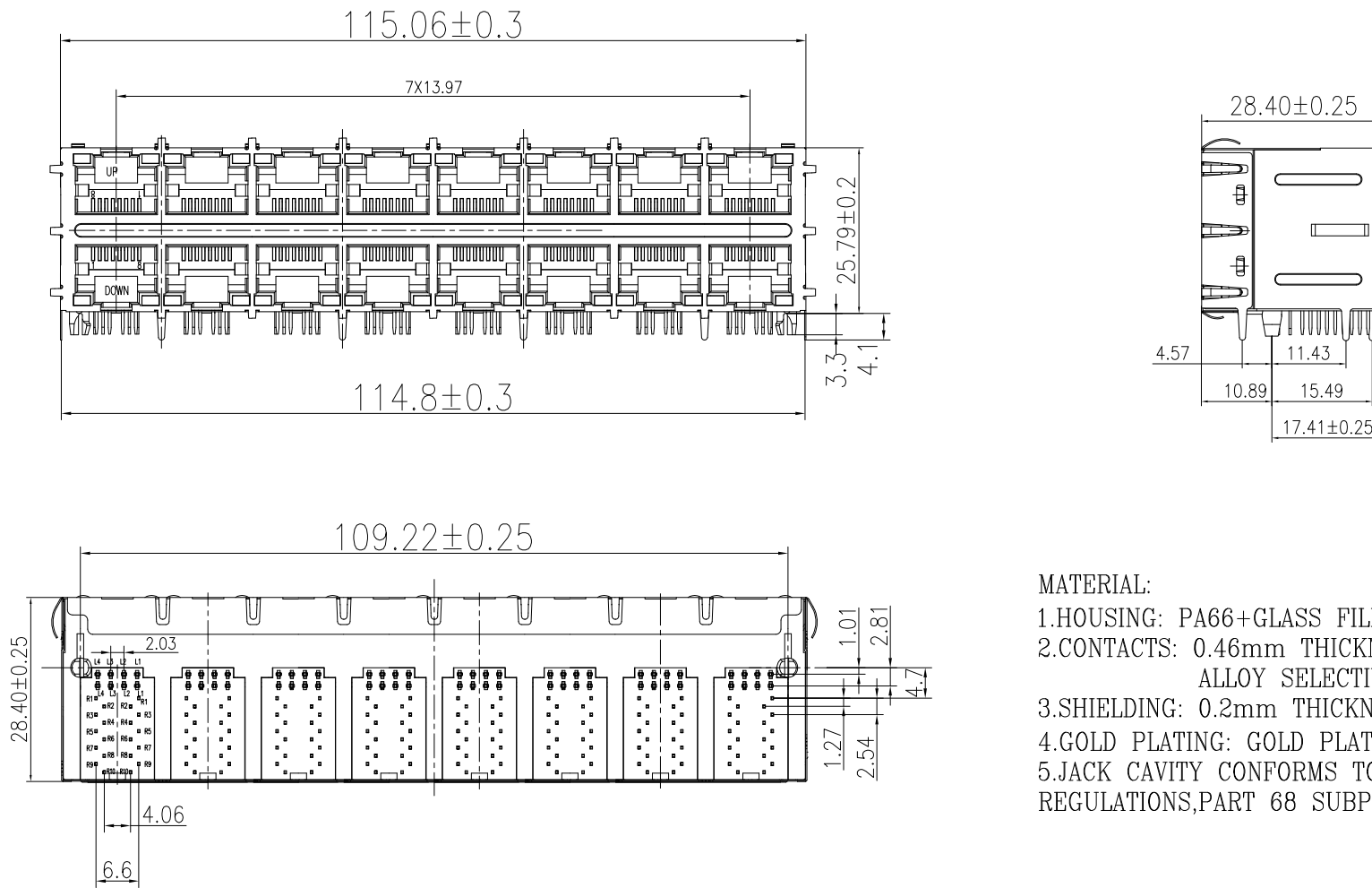

MATERIAL:

- 1.HOUSING: PA66+GLASS FILLED (UL 94V-0),BLACK
- 2.CONTACTS: 0.46mm THICKNESS PHOSPHOR BRONZE ALLOY SELECTIVE GOLD PLATING OVER NICKEL
- 3.SHIELDING: 0.2mm THICKNESS COPPER ALLOY WITH TIN PLATED
- 4.GOLD PLATING: GOLD PLATING 6u" ON CONTACT AERA
- 5.JACK CAVITY CONFORMS TO FCC RULES AND REGULATIONS,PART 68 SUBPART F

REV.	ECN. NO.	DRAWN	DATE
A	NEW	JOHN	10/04/2015

DST-conn Tech. Co., Ltd.

HSE

Compliant

⊗:QUALITY CONTROL ITEM		GENERAL TOLERANCE		PART NO.: 28BM1D-xxxx-xxx		
APPROVED		.X± 0.38	X.'± 2'	TITLE:RJ45 2X8 W/LED,SHELL,T/S		
CHECKED		.XX± 0.25	.X'± 1'	100/1000 MBPS 10P8C		
DRAWN		.XXX± 0.13		UNIT: mm	SCALE: 1:1	SHEET: 1/4
						REV.: A

說明: △ :備註 ◇ :版本變更 ① :尺寸序號 ■ :重點尺寸 ▼ :CPK尺寸

SIZE: A4

2. PCB LAYOUT :

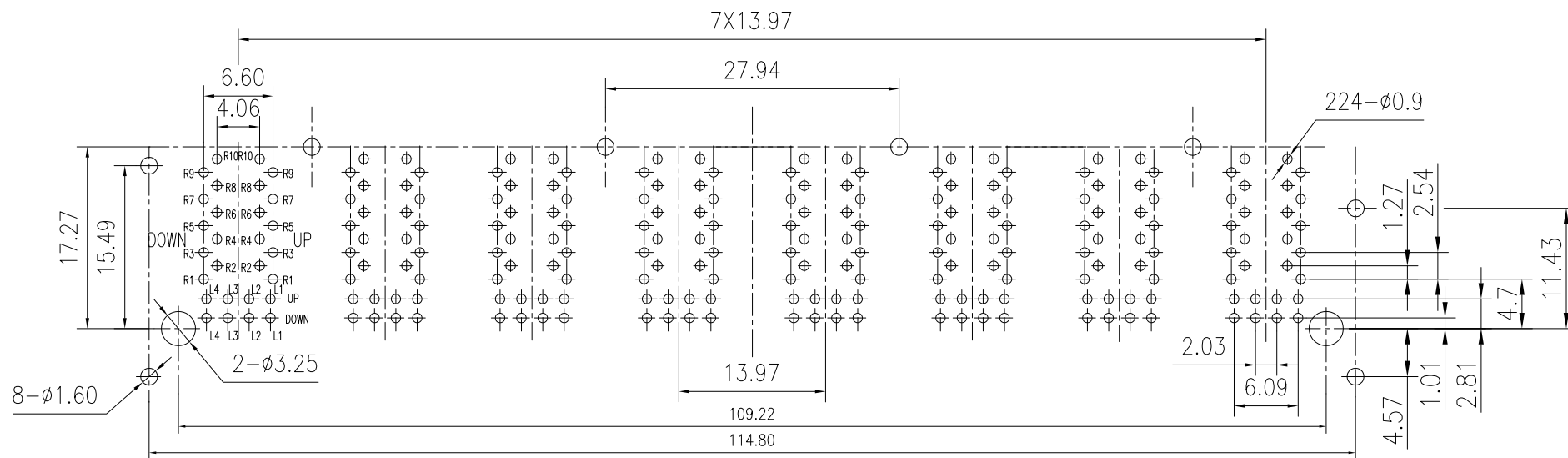

SUGGESTED PCB LAYOUT

(TOP VIEW)

DIMENSIONAL TOLERANCE: .XX ±0.05[0.002]

3. LED SCHEMATIC :



REV.	ECN. NO.	DRAWN	DATE
A	NEW	JOHN	10/04/2015

DST-conn Tech. Co., Ltd.

HSE

Compliant

⊗:QUALITY CONTROL ITEM		GENERAL TOLERANCE	PART NO.:
APPROVED		.X± 0.38 X.'± 2'	28BM1D-xxxx-xxx
CHECKED		.XX± 0.25 .X'± 1"	TITLE:RJ45 2X8 W/LED,SHELL,T/S
DRAWN		.XXX± 0.13	100/1000 MBPS 10P8C
		UNIT: mm	SCALE: 1:1
			SHEET: 2/4
			REV.: A

説明: △ :備註 ◇ :版本變更 ① :尺寸序號 ■ :重點尺寸 ▼ :CPK尺寸

SIZE: A4

4. SCHEMATIC :

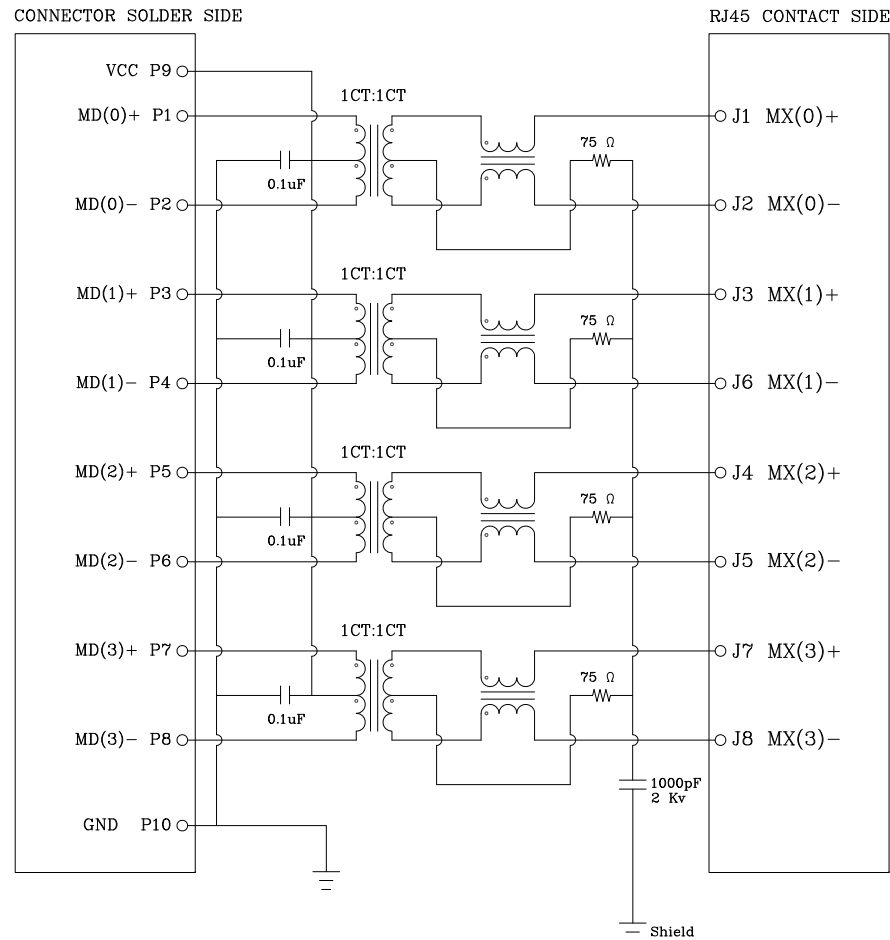

5. ELECTRICAL CHARACTERISTICS :

ELECTRICAL SPECIFICATIONS:

TEST NOTES:(25°±5°C)

- TR:(100KHz,0.1V); 100%
PINS:(P1,P2):(J1,J2)=1:1±3%;(P3,P4):(J3,J6)=1:1±3%
PINS:(P5,P6):(J4,J5)=1:1±3%;(P7,P8):(J7,J8)=1:1±3%
- LX:(100KHz,100mV,8mA, DC Bias) 100%
PINS:(P1,P2),(P3,P4),(P5,P6),(P7,P8)=350uH MINIMUM
- DCR: 100%
PINS:(J1,J2),(J3,J6),(J4,J5),(J7,J8)=1.2 OHM MAXIMUM
- HIPOT: 100%
PINS(P1,P2)TO(J1,J2),(P3,P4)TO(J3,J6)=1500VAC FOR 60 SECONDS
PINS(P5,P6)TO(J4,J5),(P7,P8)TO(J7,J8)=1500VAC FOR 60 SECONDS
- INSERTION LOSS:
-1.0dB MAXIMUM AT 1MHz TO 100MHz;
- RETURN LOSS:
-18dB MINIMUM AT 1MHz TO 30MHz;
-16dB MINIMUM AT 30MHz TO 60MHz;
-12dB MINIMUM AT 60MHz TO 100MHz;
- CROSS TALK:
-30dB MINIMUM AT 1MHz TO 100MHz
- COMMON TO COMMON MODE REJECTION:
-30dB MINIMUM AT 1MHz TO 100MHz

REV.	ECN. NO.	DRAWN	DATE
A	NEW	JOHN	10/04/2015

DST-conn Tech. Co., Ltd.

HSE

Compliant

⊗:QUALITY CONTROL ITEM		GENERAL TOLERANCE	PART NO.:
APPROVED		.X± 0.38 X.'± 2'	28BM1D-xxxx-xxx
CHECKED		.XX± 0.25 .X'± 1'	TITLE:RJ45 2X8 W/LED,SHELL,T/S
DRAWN		.XXX± 0.13	100/1000 MBPS 10P8C
UNIT: mm		SCALE: 1:1	SHEET: 3/4
			REV.: A

説明: △ :備註 ◇ :版本變更 ⑨ :尺寸序號 ■ :重點尺寸 ▼ :CPK尺寸

SIZE: A4

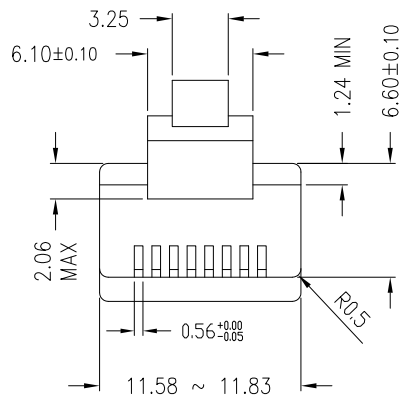

* There must be no damage to housing or locking latch. There must be no nicks or cuts in cable.
 * Durability : 750 cycles generally

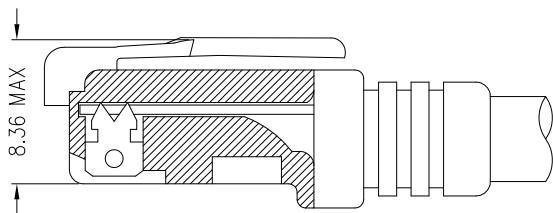

FOLLOW SPECIFICATION : FCC, PART 68, SUBPART F
 FIGURE 68.500 (C)(2)(ii)

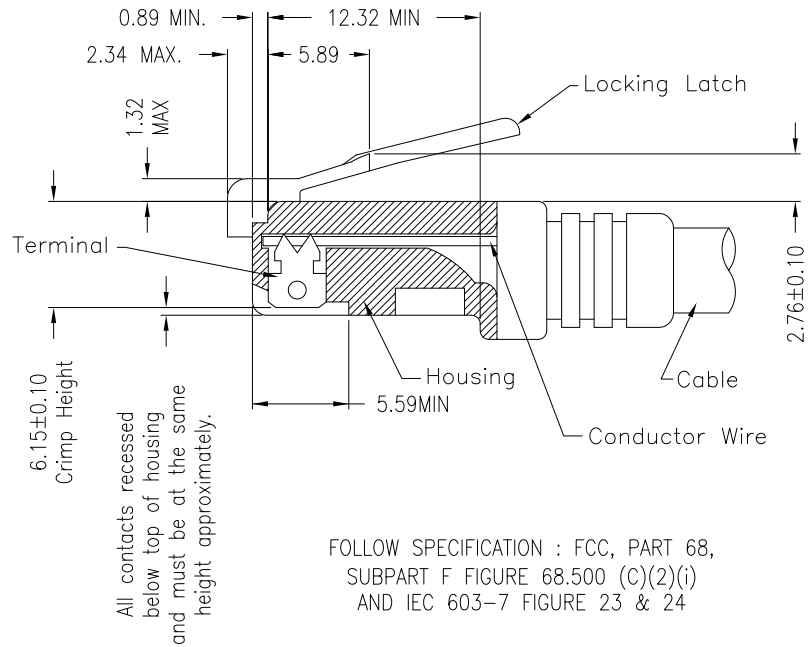

FOLLOW SPECIFICATION : FCC, PART 68,
 SUBPART F FIGURE 68.500 (C)(2)(i)
 AND IEC 603-7 FIGURE 23 & 24

STANDARD MODULAR PLUG ASSEMBLY

REV.	ECN. NO.	DRAWN	DATE
A	NEW	JOHN	10/04/2015

DST-conn Tech. Co., Ltd.

HSE

Compliant

⊗:QUALITY CONTROL ITEM		GENERAL TOLERANCE		PART NO.: 28BM1D-xxxx-xxx		
APPROVED		.X± 0.38	X.*± 2'	TITLE:RJ45 2X8 W/LED,SHELL,T/S		
CHECKED		.XX± 0.25	.X.*± 1'	100/1000 MBPS 10P8C		
DRAWN		.XXX± 0.13		UNIT: mm	SCALE: 1:1	SHEET: 4/4
						REV.: A

説明: △ :備註 ◇ :版本變更 ① :尺寸序號 ■ :重點尺寸 ▼ :CPK尺寸

SIZE: A4