

REV.	ECN NO.	DESCRIPTION	DESIGN	DATE
B	XXXXXX	修改图面与实物相符	Heibo. z	2011.12.26

SPECIFICATIONS:

- ELECTRICAL CHARACTERISTICS:
  - RATING:
  - CONTACT RESISTANCE: 30mΩ MAX.(INITIAL)
  - DIELECTRIC WITHSTANDING VOLTAGE: 500V AC FOR ONE MINUTE
  - INSULATION RESISTANCE: 100MΩ MIN. MEASURED BY 500V DC
- MECHANICAL CHARACTERISTICS:
  - INSERTION FORCE : 0.3~3.0 KGF
  - WITHDRAWAL FORCE : 0.3~3.0 KGF
- LIFE TEST: 5,000 CYCLES MIN.
- FOR REFLOW SOLDERING LEAD-FREE PROCESS.
- \* REPRESENT CRITICAL DIMENSIONS.

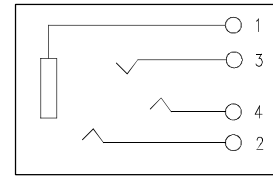
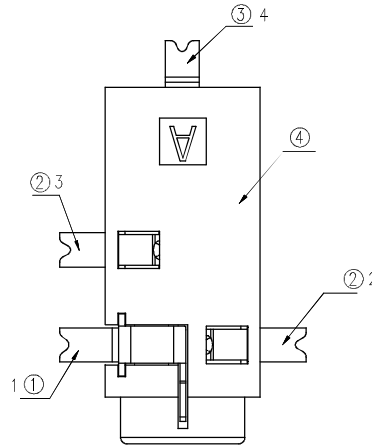
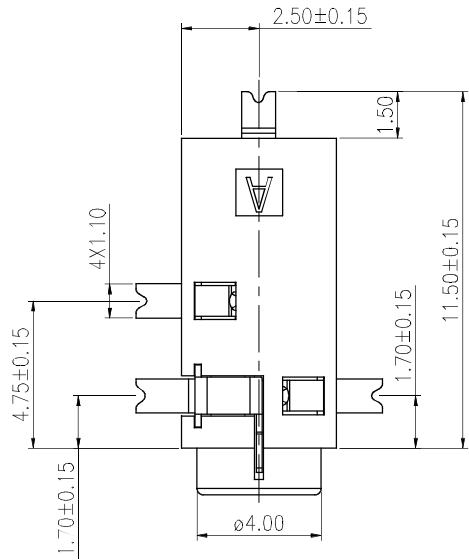

CIRCUIT DIAGRAM

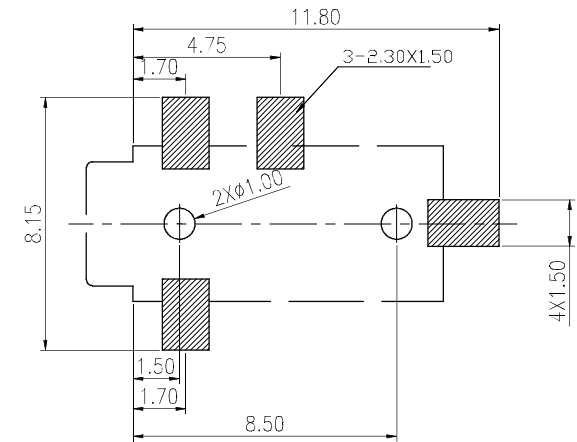

PCB LAYOUT TOP VIEW

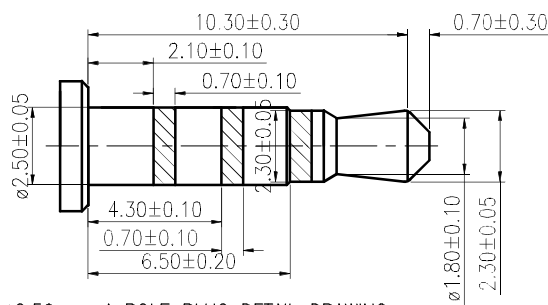
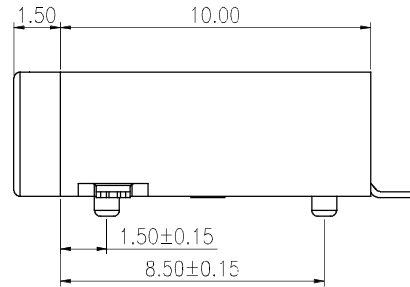
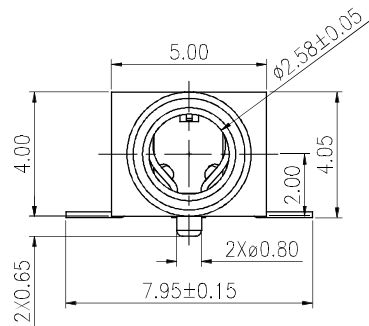

ø2.50mm 4 POLE PLUG DETAIL DRAWING

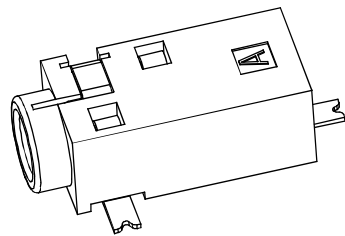

④	HOUSING PH-PJ-2533-L6	1	PA-9T	Black
③	TERMINAL MT-PJ-2572-4Q1S	1	PHOSPHOR BRONZE t=0.20	Ag-Plated
②	TERMINAL MT-PJ-2572-2Q1S	2	PHOSPHOR BRONZE t=0.20	Ag-Plated
①	TERMINAL MT-PJ-2572-1Q1S	1	PHOSPHOR BRONZE t=0.20	Ag-Plated
NO.	DESCRIPTION	QTY	MATERIAL	PLATING & COLOR

UNLESS OTHERWISE SPECIFIED TOLERANCES

**DST**-conn Tech. Co., Ltd.

DECIMALS:		ANGLES:		DWG NO.	PART NAME: EARPHON JACK
DIM	TOL	DIM	TOL	DESIGN: Heibo. z 2011.12.26	
X.	±0.50	X.	±2°	CHECK:	PART NO. A22680S-41DBNR
X.X	±0.30	X.X	±1°		
X.XX	±0.20	X.XX	—	APPROVED	REV. UNIT: SHEET: B mm 1/1
X.XXX	±0.10	X.XXX	—		