

RoHS Compliant

SYMBOL	REV.	REVISION	APPROVAL	DATE
	A	新版圖紙	Winky	2015. 04. 29

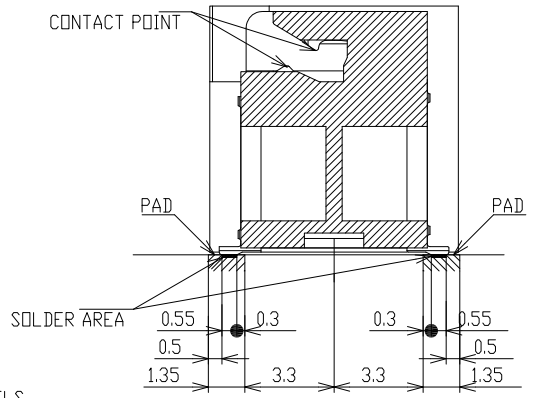
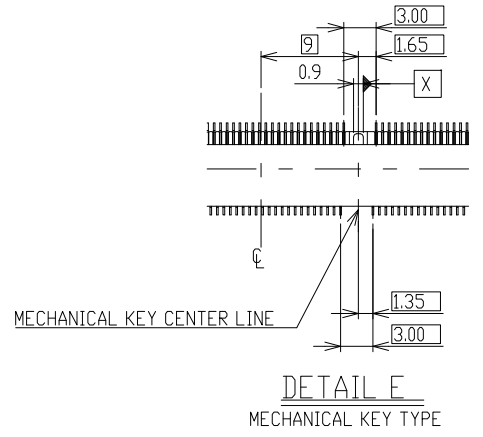
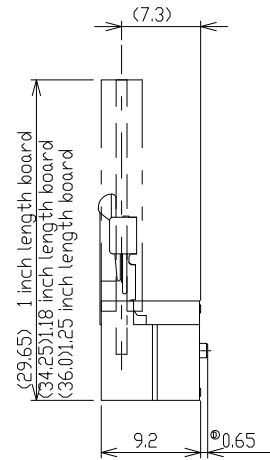
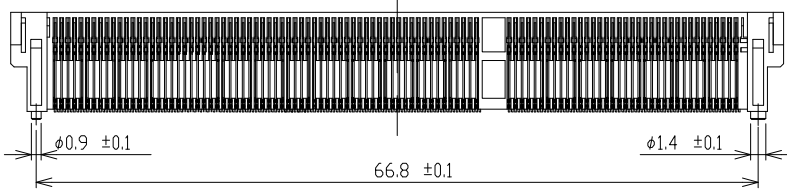
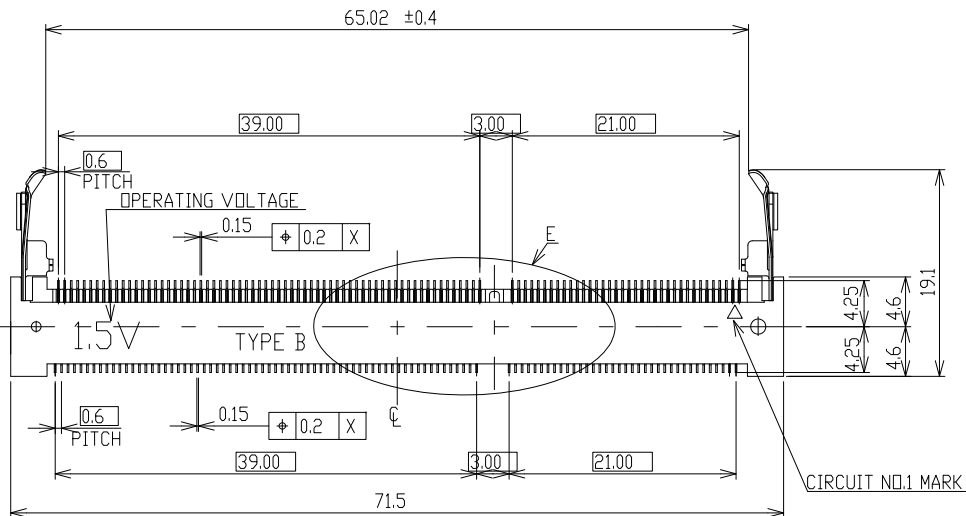
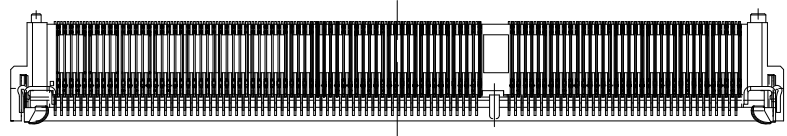

NOTES.

1. MATERIAL; HOUSING-LCP, UL94V-0, COLOR:BLACK
CONTACT: COPPER ALLOY
METAL LATCH: SUS
2. PLATING: CONTACT (CONTACT POINT, SOLDER AREA):
Au PLATE 0.0075 μm MIN, Ni UNDER PLATE 1.5 μm MIN.
3. MUST BE MEASURED FLOATING AMOUNT OF CONTACT TAILS
FROM DATUM SURFACE IS 0.1mm MAX.

4. NOT TO SCALE.
5. TOLERANCES NON-CUMULATIVE
6. FOR SOCKET OF THE OTHER COMPANIES

1.5V	DI12-DSEB0204xLH	DI12-DSEB0204TLH	DI12-DSEB0204RLH
POWER SUPPLY	PART NO. OF CONNECTOR	PART NO. OF PACKAGED PRODUCT (WITH HARD TARY)	PART NO. OF PACKAGED PRODUCT (WIT EMOSS TAPE)

DST-conn Tech. Co., Ltd.

COPYRIGHT RESERVED, PLEASE DO NOT COPY.

PART NAME	DDR S.O DIMM SOCKET II-9.2 TYPE B SMALL LATCH FOR 204PIN	DRAWING	Winky	DWG. No.	DI12	
PART NO.	DI12-DSEB0204xLH	CHECK	Roy	REV.	A	
UNIT : mm	GENERAL TOLERANCE	±0.20	APPROVAL	John	DATE	2015. 04. 29
			ANGLE	±2°	SCALE	1:1

F E D C B A

RoHS Compliant

SYMBOL	REV.	REVISION	APPROVAL	DATE
	A	新版圖紙	Winky	2015. 04. 29

1
2
3
4

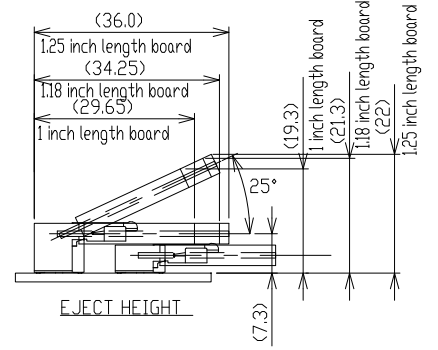
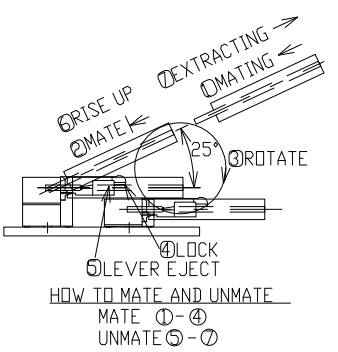
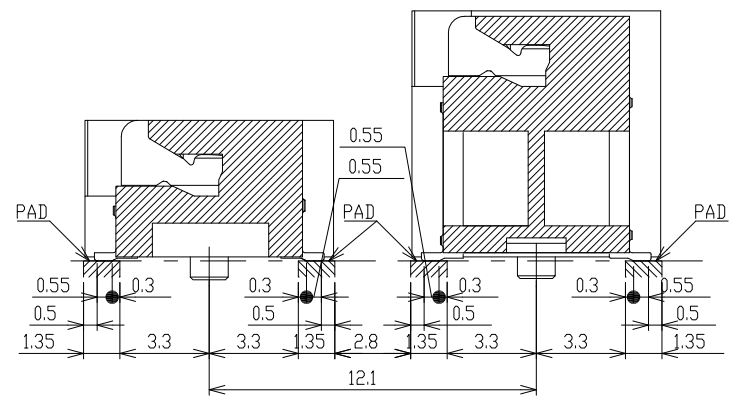
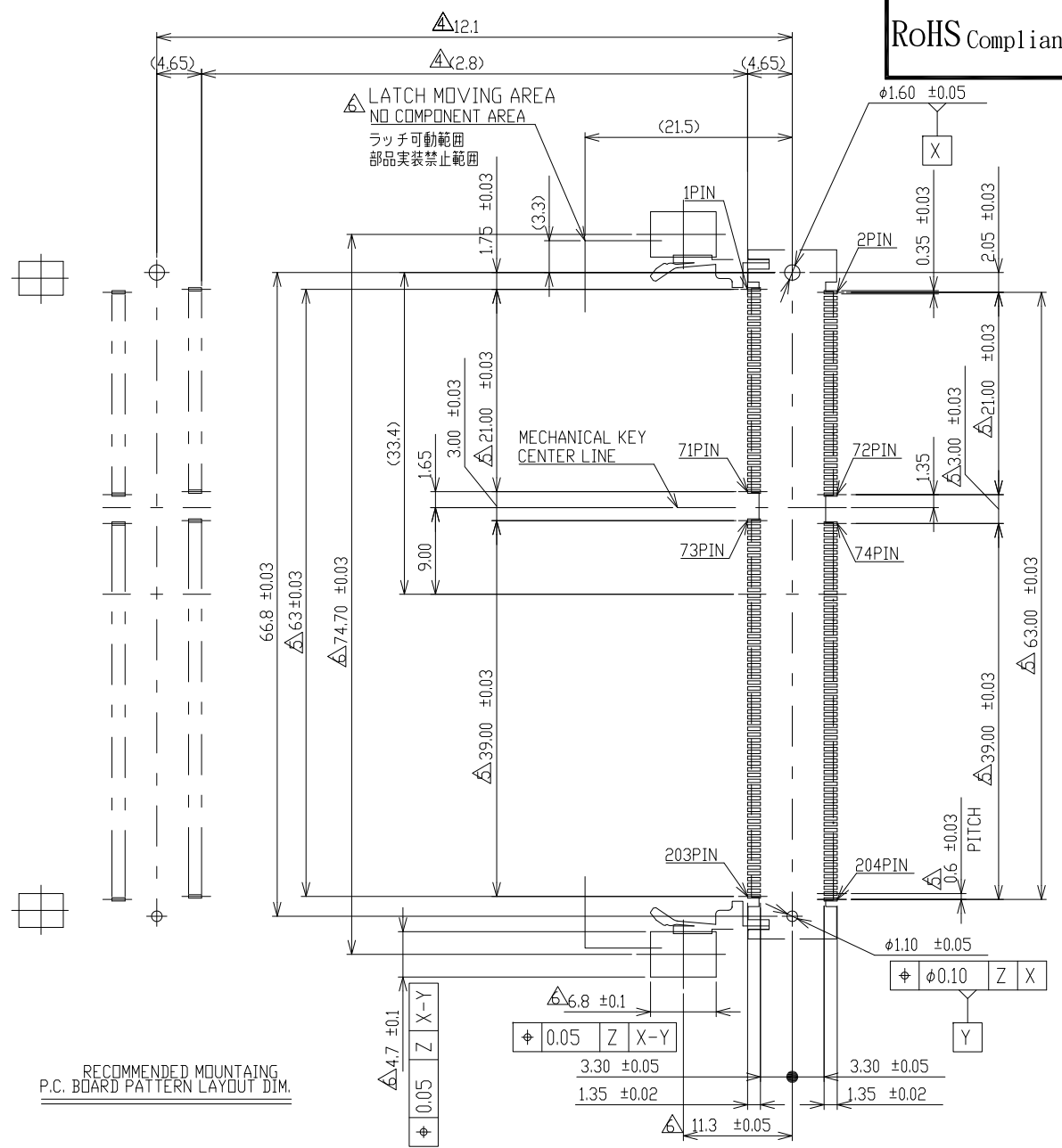

RECOMMENDED MOUNTING P.C. BOARD PATTERN LAYOUT DIM.

DST-conn Tech. Co., Ltd.

COPYRIGHT RESERVED, PLEASE DO NOT COPY.

PART NAME		DDR S.O DIMM SOCKET II-9.2 TYPE B SMALL LATCH FOR 204PIN		DRAWING		Winky		DWG. No.		D112	
PART NO.		D112-DSEB0204xLH		CHECK		Roy		REV.		A	
UNIT :		GENERAL TOLERANCE		ANGLE		APPROVAL		DATE		2015. 04. 29	
mm		±0.20		±2°		SCALE		PAGE		2 OF 6	

RoHS Compliant

SYMBOL	REV.	REVISION	APPROVAL	DATE
	A	新版圖紙	Winky	2015. 04. 29

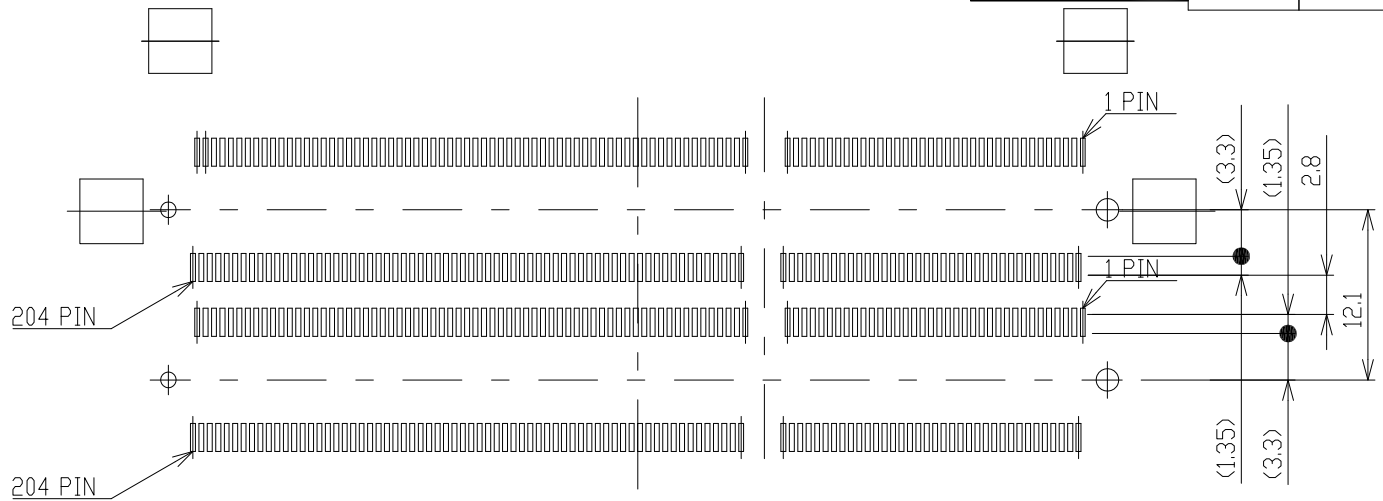

RECOMMENDED MOUNTING
P.C. BOARD PATTERN LAYOUT DIM.

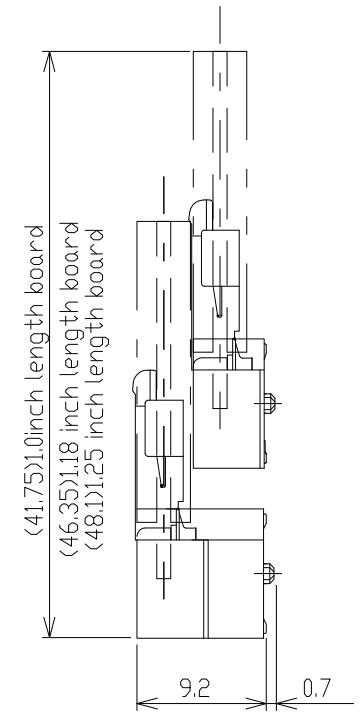
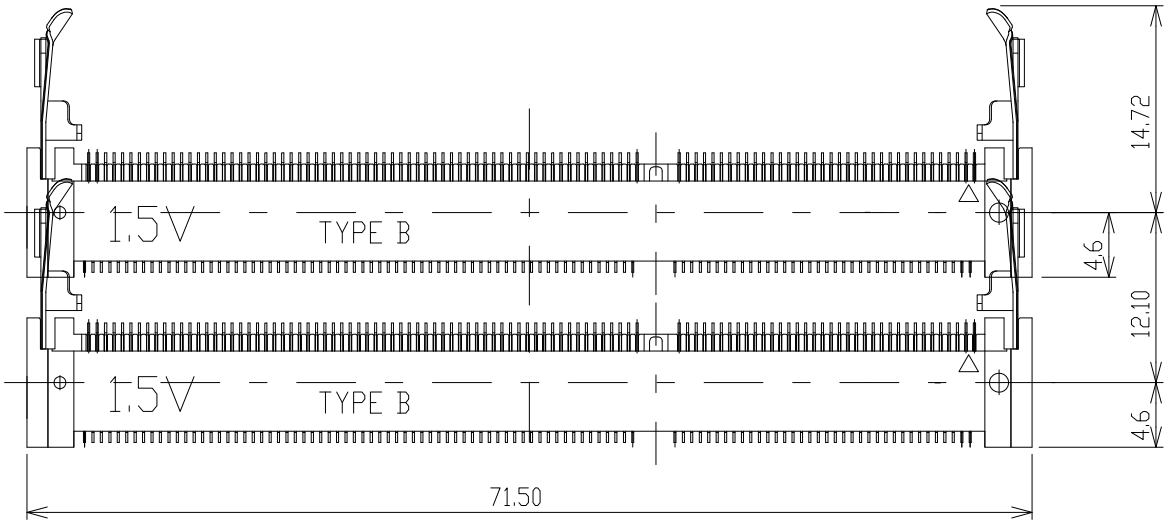

Combination Dimension for H=5.2 connector
(Only the combination of the P/N DI10(H=5.2) and DI12(H=9.2) is possible.)

DST-conn Tech. Co., Ltd.

COPYRIGHT RESERVED, PLEASE DO NOT COPY.

	PART NAME	DDR S.O DIMM SOCKET H=9.2 TYPE B SMALL LATCH FOR 204PIN	DRAWING	Winky	DWG. No.	DI12
	PART NO.	DI12-DSEB0204xLH	CHECK	Roy	REV.	A
	UNIT : mm	GENERAL TOLERANCE	APPROVAL	John	DATE	2015. 04. 29
		±0.20	SCALE	1:1	PAGE	4 OF 6

F

E

D

C

B

A

RoHS Compliant

SYMBOL

REV.

REVISION

APPROVAL

DATE

A

新版圖紙

Winky

2015. 04. 29

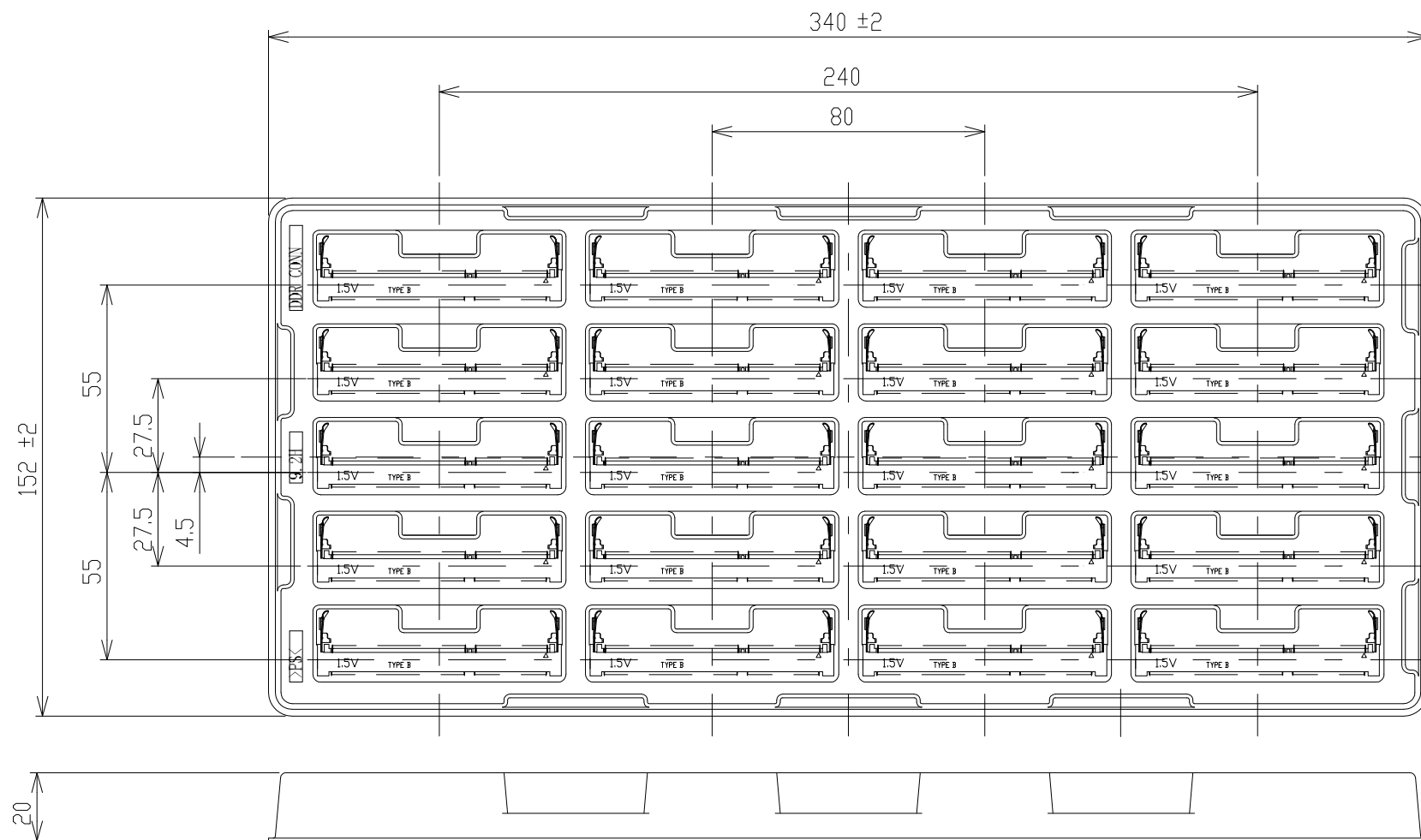

SOFT TRAY PACKAGING

20

D112-DSEB0204xLH

D112-DSEB0204TLH

QTY

PART NO. OF
CONNECTORPART NO. OF
PACKAGED PRODUCT
(WITH SOFT TARY)

DST-conn Tech. Co., Ltd.

PART NAME

DDR S.O DIMM SOCKET H=9.2 TYPE B SMALL LATCH FOR 204PIN

DRAWING

Winky

DWG. No.

D112

PART NO.

D112-DSEB0204xLH

CHECK

Roy

REV.

A

UNIT :
mm

GENERAL TOLERANCE

±0.50



ANGLE

±2°

APPROVAL

John

DATE

2015. 04. 29

SCALE

1:1

PAGE

5 OF 6

COPYRIGHT RESERVED, PLEASE DO NOT COPY.

F

E

D

C

B

A

RoHS Compliant

SYMBOL	REV.	REVISION	APPROVAL	DATE
	A	新版圖紙	Winky	2015. 04. 29

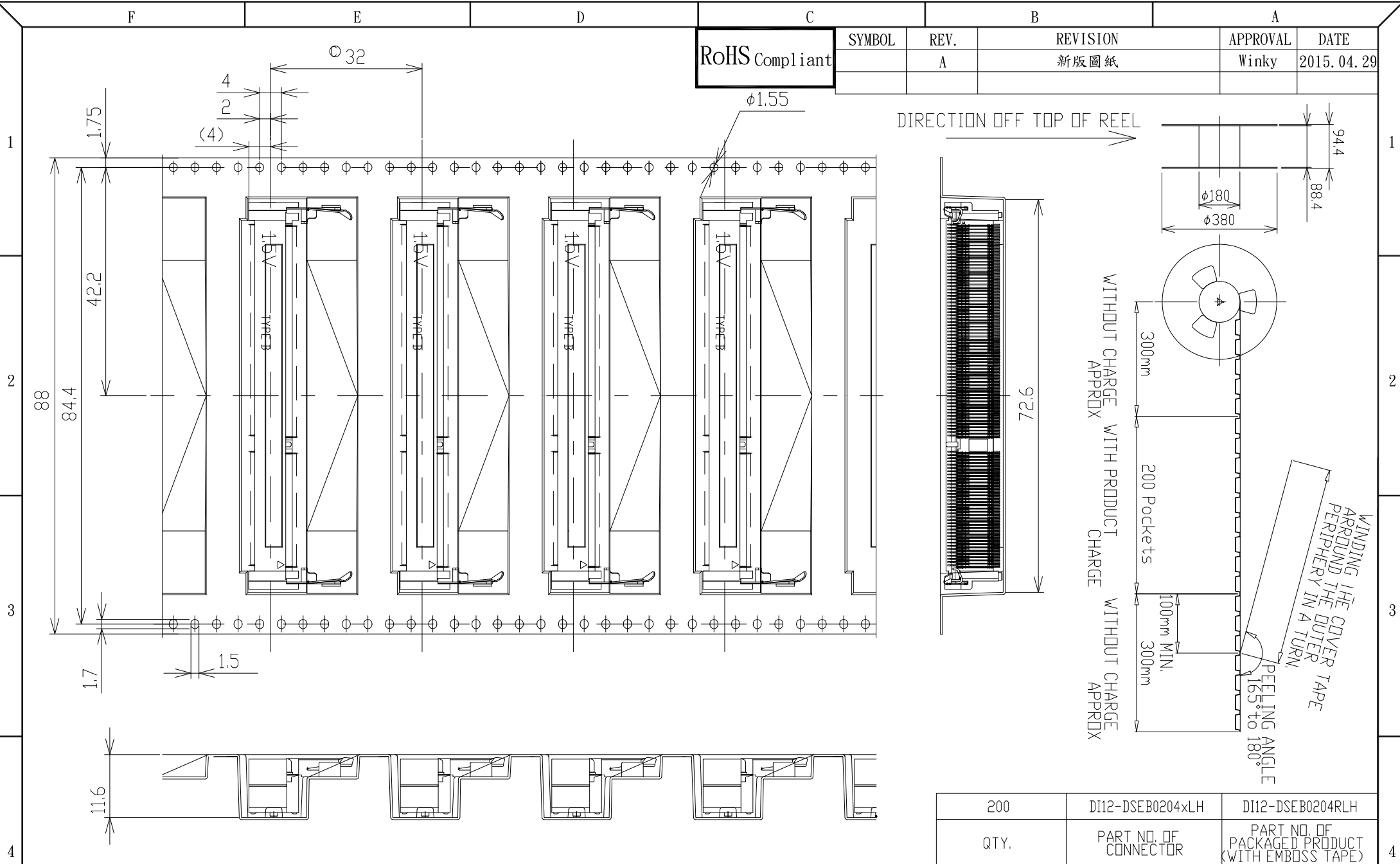

200	DI12-DSEB0204xLH	DI12-DSEB0204RLH
QTY.	PART NO. OF CONNECTOR	PART NO. OF PACKAGED PRODUCT (WITH EMBOSS TAPE)

DST-conn Tech. Co., Ltd.

PART NAME	DDR S.O DIMM SOCKET H=9.2 TYPE B SMALL LATCH FOR 204PIN	DRAWING	Winky	DWG. No.	DI12
PART NO.	DI12-DSEB0204xLH	CHECK	Roy	REV.	A
UNIT : mm	GENERAL TOLERANCE	±0.50	ANGLE	DATE	2015. 04. 29
			±2°	SCALE	1:1

COPYRIGHT RESERVED, PLEASE DO NOT COPY.