

F

E

D

C

B

A

RoHS Compliant

SYMBOL

REV.

REVISION

APPROVAL

DATE

A

新版圖紙

Winky

2013. 10. 07

NOTES:

1. MATERIAL:

HOUSING: HIGH TEMPERATURE THERMO PLASTIC UL94V-0

TERMINAL: COPPER ALLOY

SOLDER PEG: COPPER ALLOY

2. FINISH:

TERMINAL:

CONTACT AREA: SEE CHARTS

SOLDERING AREA: SEE CHARTS

UNDER PL.: NICKEL PL. 50 μ" THK MIN.

3. THIS PRODUCT DOESN'T CONTAIN ENVIRONMENTAL HAZARDOUS PER DIRECTIVE 2002/95/EC FOR RoHS COMPLIANT.

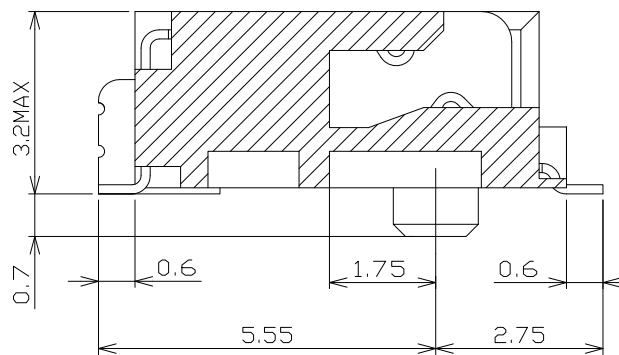
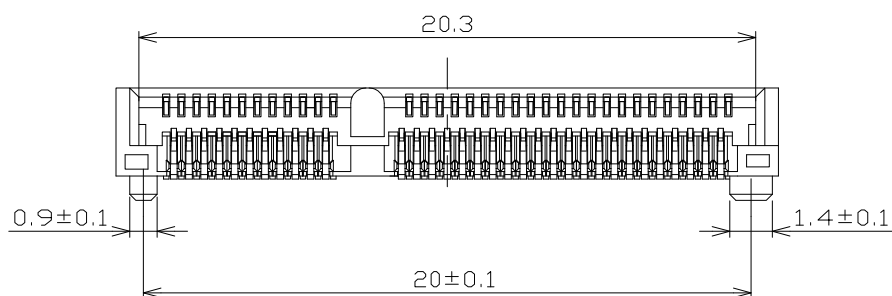
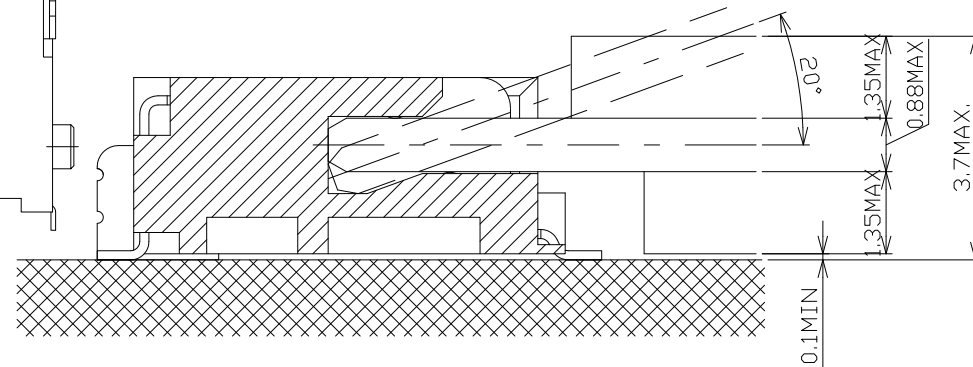
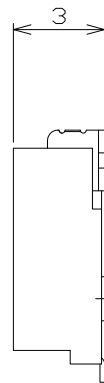
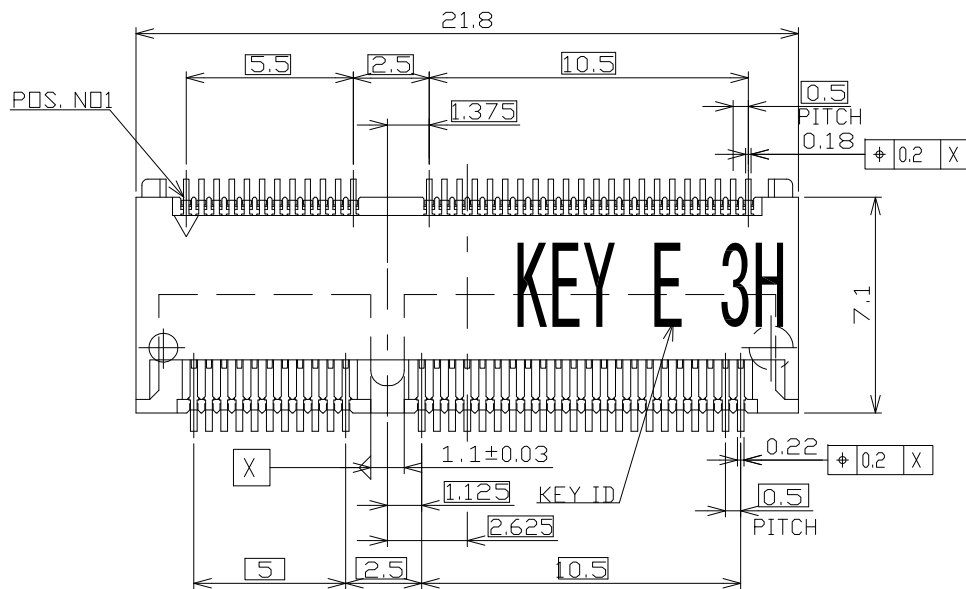
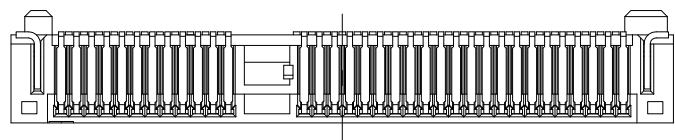

KEY E	Au:30 μ"	DI19-NSEB567RLH
	Au:15 μ"	DI19-NSEB467RLH
	GOLD FLASH	DI19-NSEB067RLH
KEY ID	FINISH	PART NO.

COLOR:BLACK  
GENERAL TOLERANCE ±0.20

**DST**-conn Tech. Co., Ltd.

COPYRIGHT RESERVED, PLEASE DO NOT COPY.

PART NAME

NGFF CONN. 3H KEY ID E TYP

DRAWING

Winky

DWG. No.

DI19

PART NO.

DI19-NSEBx67RLH

CHECK

Roy

REV.

A



UNIT : TOLERANCE UNLESS  
mm OTHERWISE SPECIFIED

ANGLE

APPROVAL

John

DATE

2013. 10. 07

±3°

SCALE

1:1

PAGE

1 OF 4

F

E

D

C

B

A

RoHS Compliant

SYMBOL	REV.	REVISION	APPROVAL	DATE
	A	新版圖紙	Winky	2013. 10. 07

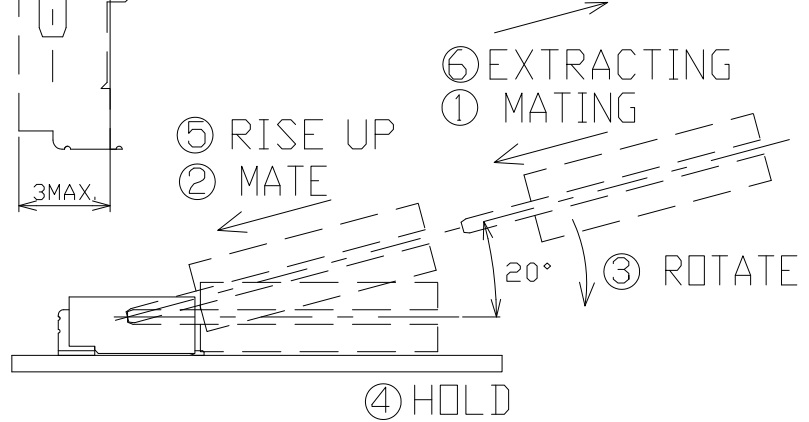
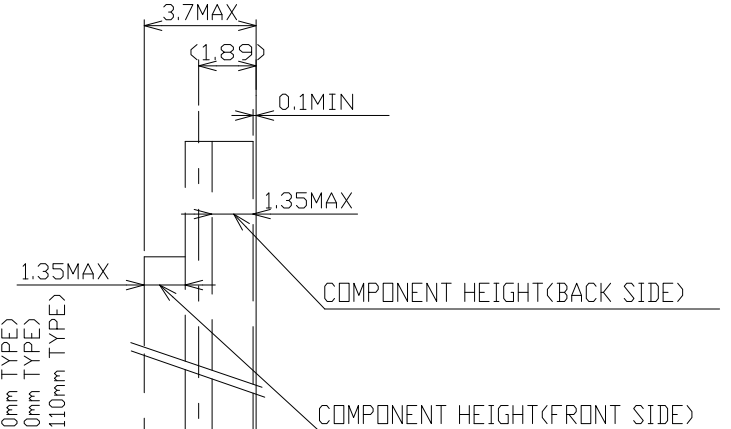
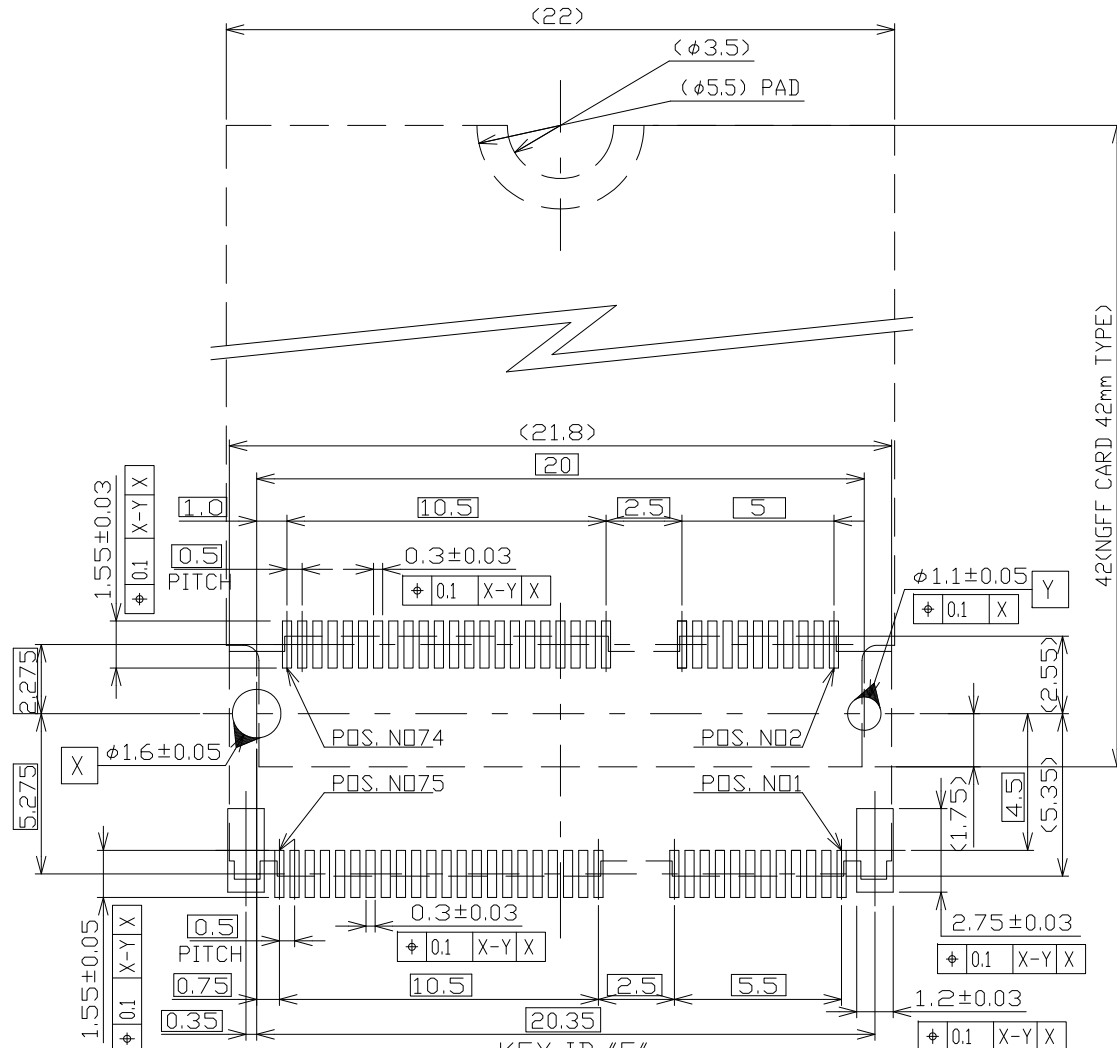

KEY ID "E"  
RECOMMENDED P.C.BOARD LAYOUT

COLOR: BLACK  
GENERAL TOLERANCE ±0.20

**DST-conn Tech. Co., Ltd.**

COPYRIGHT RESERVED, PLEASE DO NOT COPY.

PART NAME		NGFF CONN. 3H KEY ID E TYP		DRAWING		Winky		DWG. No.		D119	
PART NO.		D119-NSEBx67RLH		CHECK		Roy		REV.		A	
UNIT : mm	TOLERANCE UNLESS OTHERWISE SPECIFIED			ANGLE	APPROVAL	John	DATE	2013. 10. 07			
				±3°	SCALE	1:1	PAGE	2 OF 4			

RoHS Compliant

SYMBOL	REV.	REVISION	APPROVAL	DATE
	A	新版圖紙	Winky	2013. 10. 07

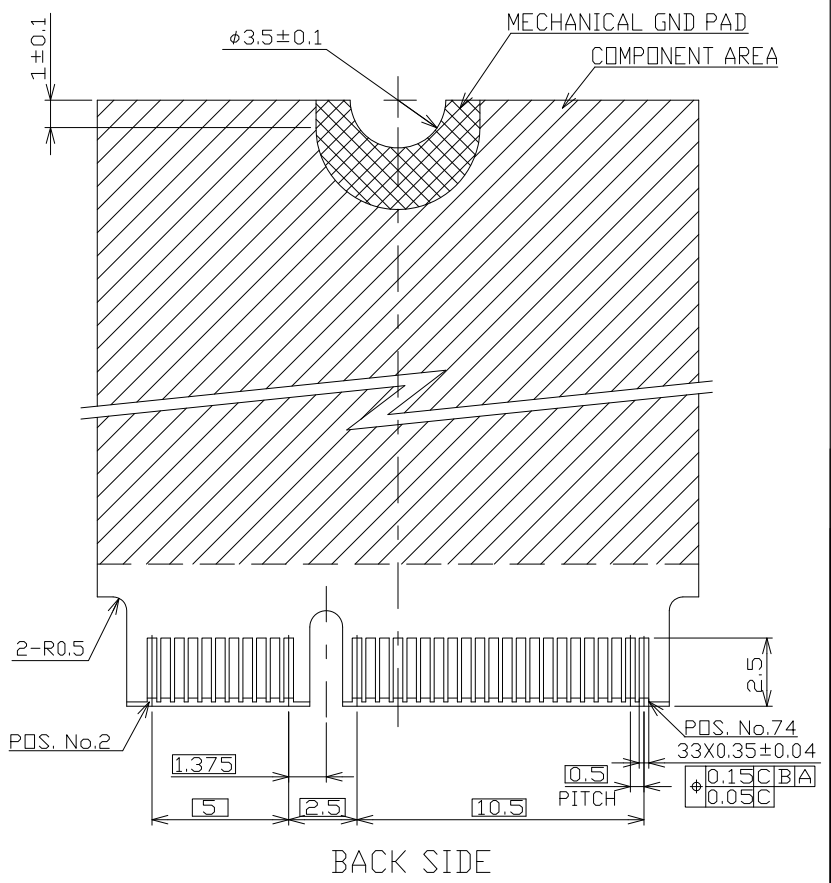
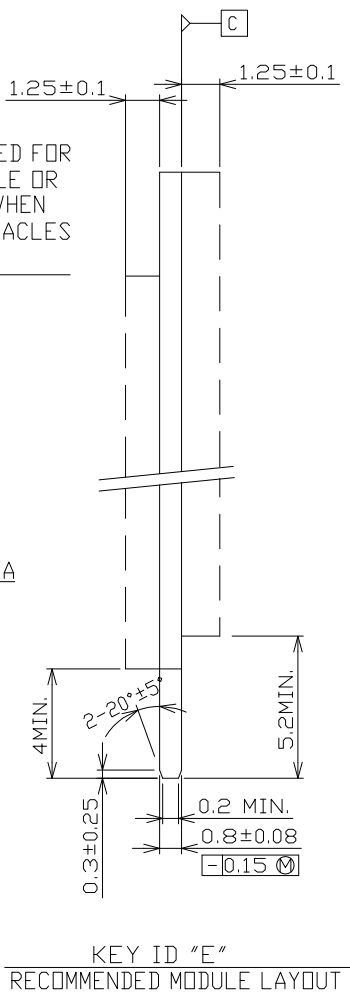
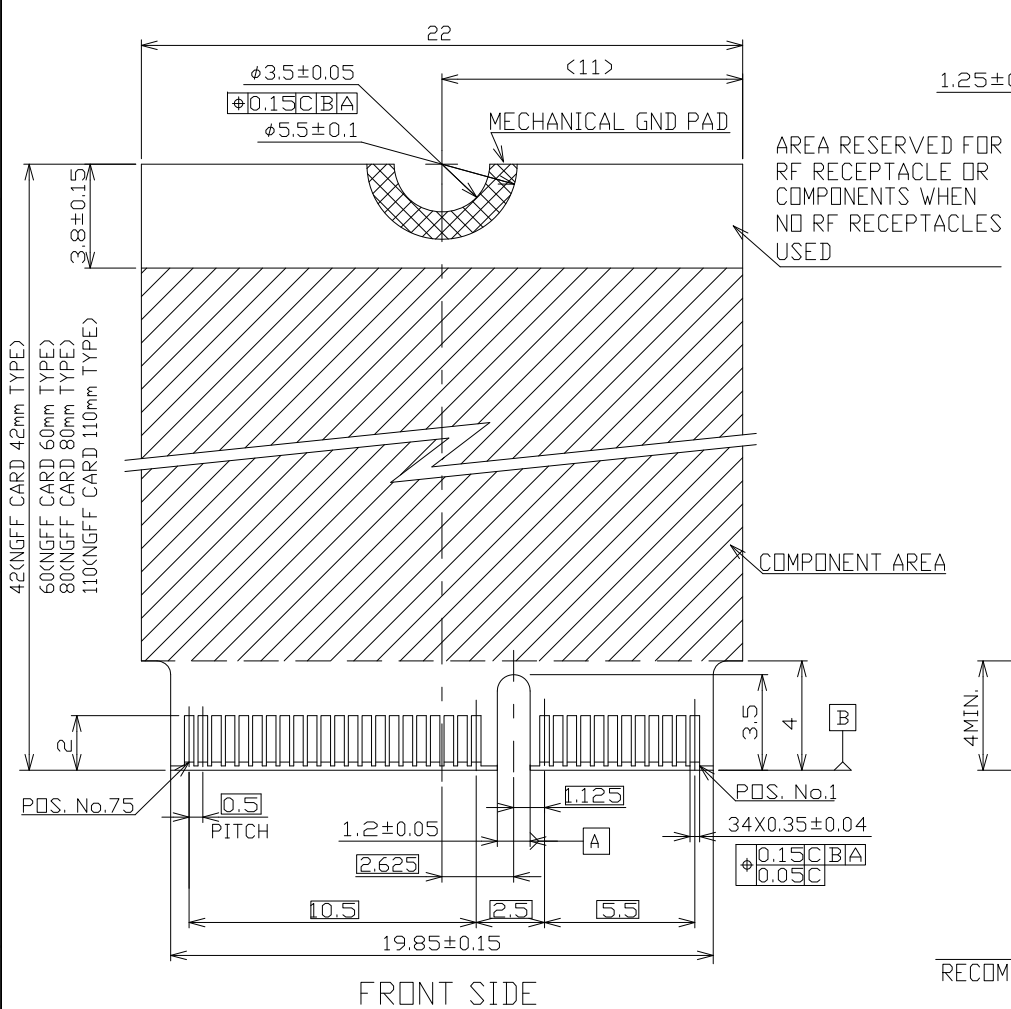

COLOR: BLACK  
GENERAL TOLERANCE ±0.15

**DST**-conn Tech. Co., Ltd.

COPYRIGHT RESERVED, PLEASE DO NOT COPY.

PART NAME	NGFF CONN. 3H KEY ID E TYP	DRAWING	Winky	DWG. No.	D119
PART NO.	DI19-NSEBx67RLH	CHECK	Roy	REV.	A
UNIT : mm	TOLERANCE UNLESS OTHERWISE SPECIFIED	ANGLE	John	DATE	2013. 10. 07
		±3°	SCALE	1:1	PAGE

RoHS Compliant

SYMBOL	REV.	REVISION	APPROVAL	DATE
	A	新版圖紙	Winky	2013. 10. 07

DIRECTION OFF TOP OF REEL

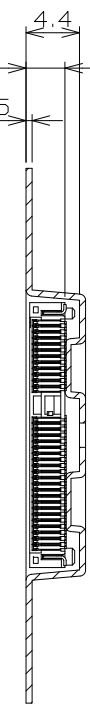
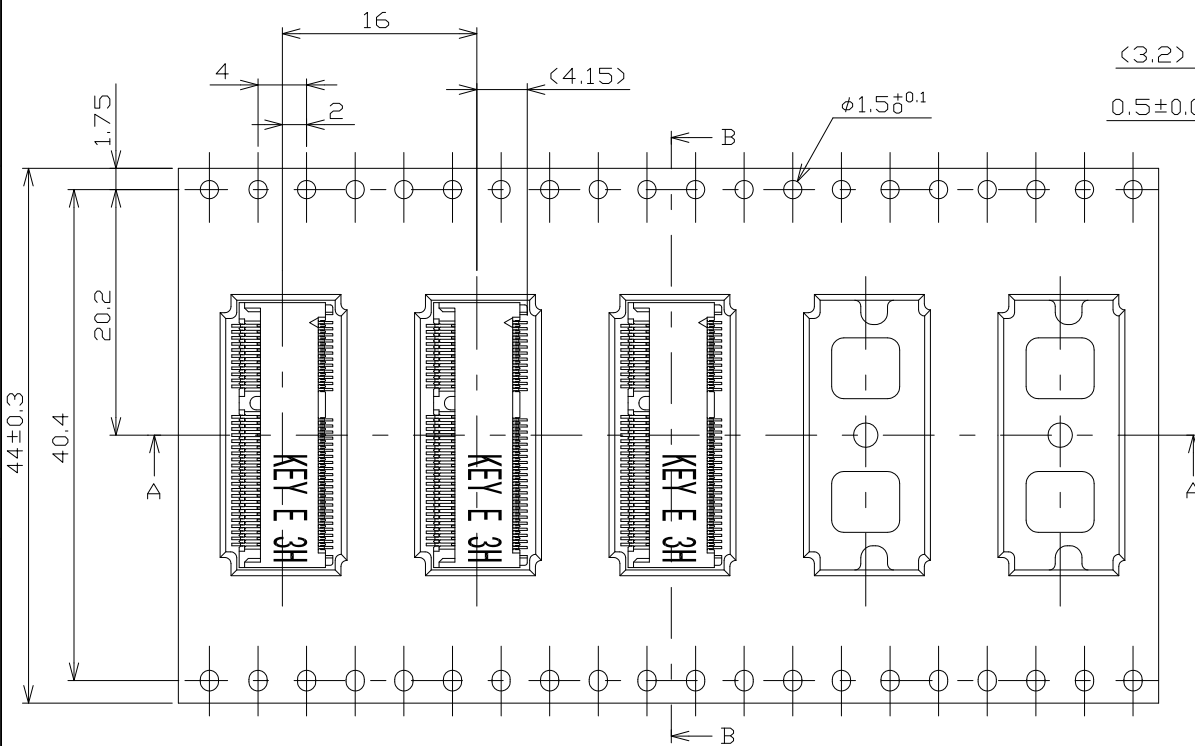
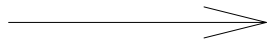

SECT B-B

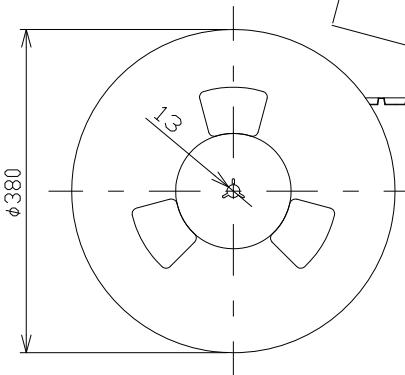

WINDING THE COVER TAPE  
AROUND THE OUTER  
PERIPHERY IN A TURN,  
カバートープ リーダー部 剥離角度  
外周一巻 165° to 180°

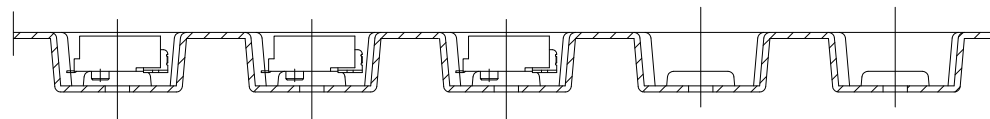

SECT A-A

NOTES:

1. THE DIRECTION OF EACH CONNECTOR ON A EMBOSS IS REFERED TO THIS DRAWING.
2. GENERAL TOLERANCE :  $\pm 0.5$  ,  $\pm 3^\circ$
3. PACKAGED IN EMBOSS TAPE AND PLASTIC REEL 1200 PCS PRE REEL.

COLOR: BLACK

GENERAL TOLERANCE  $\pm 0.20$

**DST**-conn Tech. Co., Ltd.

COPYRIGHT RESERVED, PLEASE DO NOT COPY.

PART NAME	NGFF CONN. 3H KEY ID E TYP	DRAWING	Winky	DWG. No.	D119
PART NO.	DI19-NSEBx67RLH	CHECK	Roy	REV.	A
UNIT : mm	TOLERANCE UNLESS OTHERWISE SPECIFIED	ANGLE	John	DATE	2013. 10. 07
		$\pm 3^\circ$	SCALE	1:1	PAGE