

F

E

D

C

B

A

RoHS Compliant
Halogen Free

SYMBOL

REV.

REVISION

APPROVAL

DATE

A

新版圖紙

Winky

2012/08/01

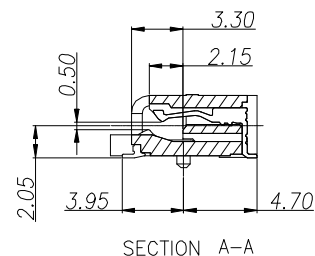
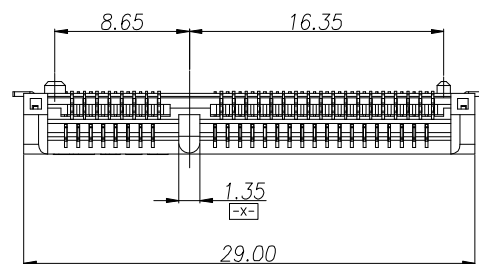

SECTION A-A

DATA CODE: XX XX X X X

Group
Plant
Day
Week
Year

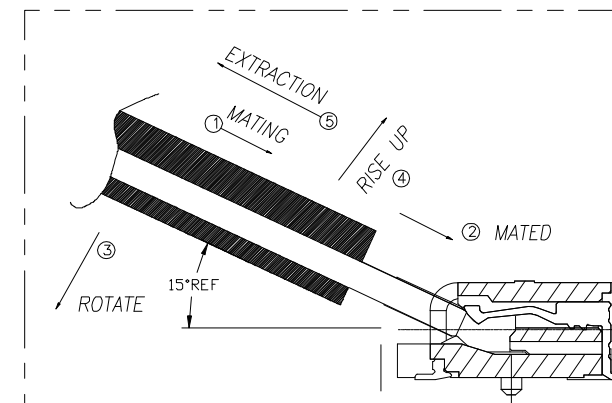
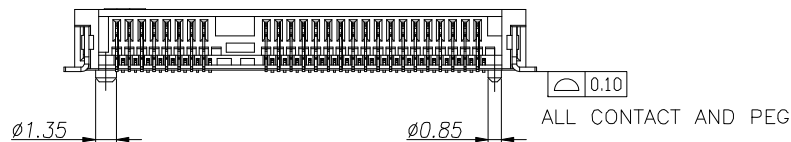
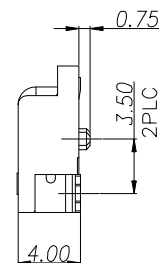
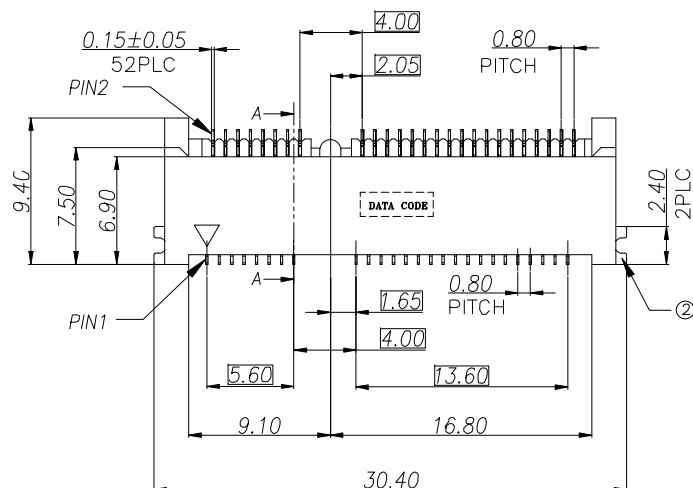

HOW TO MATE AND UNMATE

MATE ① → ②
UNMATE ④ → ⑤

DST-conn Tech. Co., Ltd.

COPYRIGHT RESERVED, PLEASE DO NOT COPY.

PART NAME		Mini PCI EXPRESS 52P 4.0H Conn		DRAWING		Winky		DWG. No.		D130		
PART NO.		DI29-WSExx52xxZ		CHECK		Roy		REV.		A		
UNIT :	TOLERANCE UNLESS	X.X ± 0.30		ANGLE	APPROVAL		John		DATE		2012/08/01	
	OTHERWISE SPECIFIED	X.XX ± 0.20			SCALE		1:1		PAGE		1 OF 3	
mm		X.XXX ± 0.10		±2°								

F

E

D

C

B

A

RoHS Compliant
Halogen Free

SYMBOL	REV.	REVISION	APPROVAL	DATE
	A	新版圖紙	Winky	2012/08/01

NOTES:

1. Material:
 - Housing: LCP High Temperature Thermoplastic, UL 94V-0;
 - Terminal: Copper Ally;
 - PEG: Copper Alloy;
2. Electrical characteristics:
 - a. Voltage rating: 50V AC per contact;
 - b. Current rating: 0.5 AMP per contact;
 - c. Dielectric withstanding voltage: 300V AC RMS (Min);
 - d. Insulation resistance: 500 Megohms at 500V DC Min;
 - e. Contact resistance: 55 milliohms Max (initial);
3. Mechanical characteristics:
 - a. Insertion force: 2.3kgf Max;
 - b. Withdrawal force: 2.3kgf Max;
 - c. Durability: insert & withdraw 50 cycles;

ORDER INFORMATION:

DI29-WSE x x 52 x x Z

Color:
B: Black
W: White

Environment Protection:
L: for RoHS
G: for GP
H: for Halogen-free

Plating:
0: Pin Flash Gold
1: Pin Gold 3u"
2: Pin Gold 5u"
3: Pin Gold 10u"
4: Pin Gold 15u"

Packing:
E: Tube
R: Reel
T: Tray

52: No. of Pins

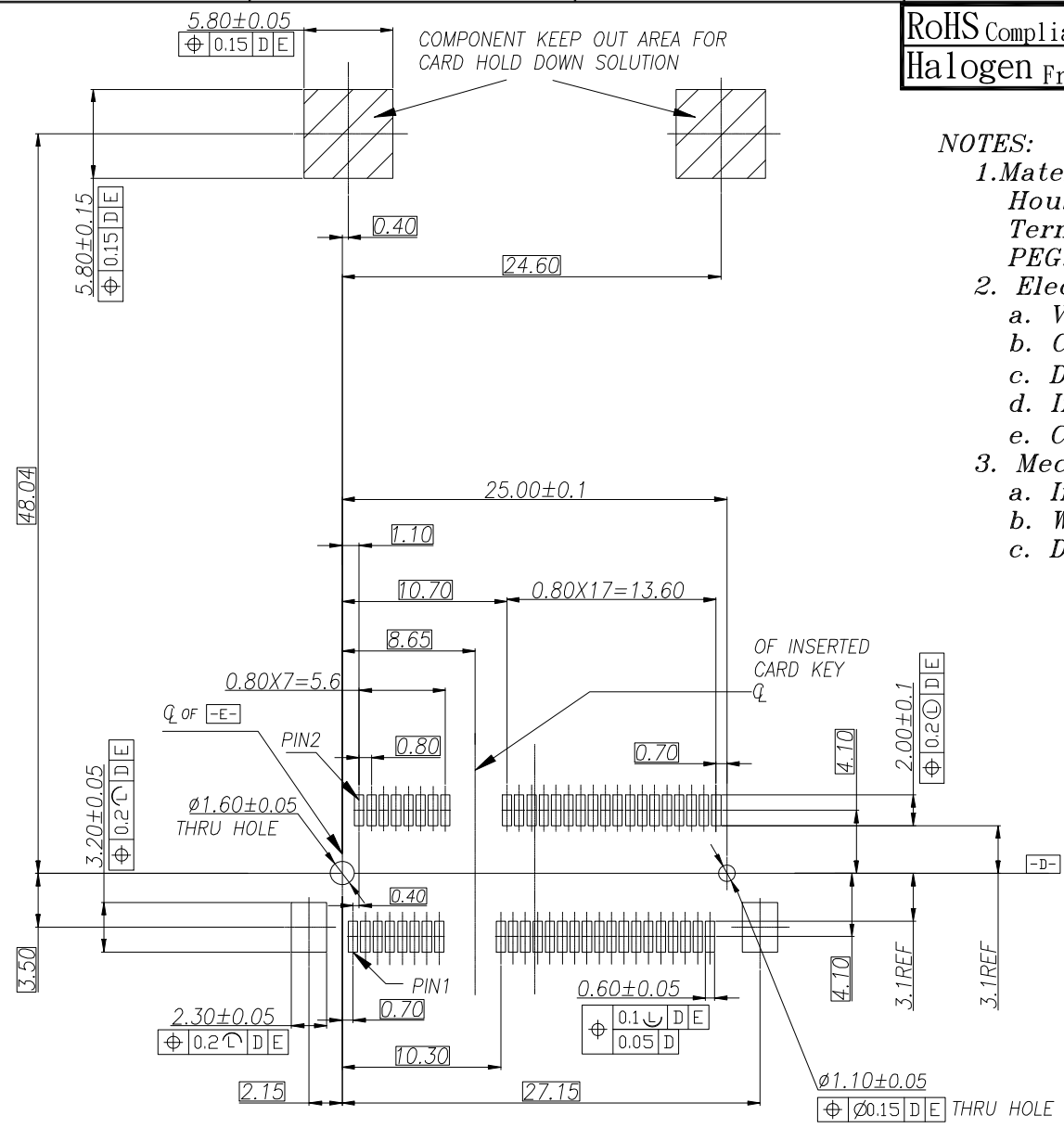

RECOMMENDED PCB LAYOUT
THICKNESS: 1.20±0.05mm

DST-conn Tech. Co., Ltd.

COPYRIGHT RESERVED, PLEASE DO NOT COPY.

PART NAME		Mini PCI EXPRESS 52P 4.0H Conn		DRAWING	Winky	DWG. No.	DI30
PART NO.		DI29-WSExx52xxZ		CHECK	Roy	REV.	A
UNIT : mm	TOLERANCE UNLESS OTHERWISE SPECIFIED	X.X ± 0.30	ANGLE ±2°	APPROVAL	John	DATE	2012/08/01
		X.XX ± 0.20		SCALE	1:1	PAGE	2 OF 3
		X.XXX ± 0.10					

RoHS Compliant
Halogen Free

SYMBOL	REV.	REVISION	APPROVAL	DATE
	A	新版圖紙	Winky	2012/08/01

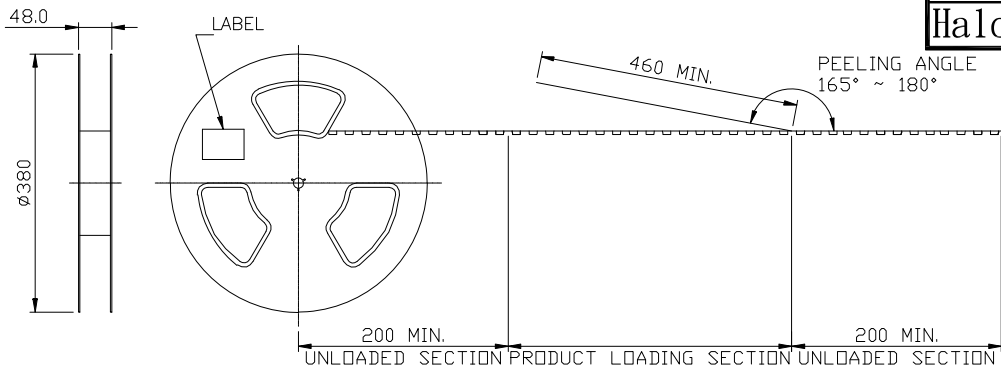

NOTES :

- MATERIAL :
COVER TAPE : ANTISTATIC P.S T=0.05±0.01 ,COLOR: :CLEAR
CARRIER TAPE : ANTISTATIC P.S T=0.40±0.10
REEL : PS UL94V-0
CARTON: CORRUGATED FIBER
- DIMENSION :
REEL : SEE DRAWING
SHIPPING BOX: 385X385X248mm
- QUANTITY : SEE TABLE
- PEELING RESISTANCE : 10gf~130gf (for 12~56mm)
- PEELING SPEED : 300mm/MINUTES

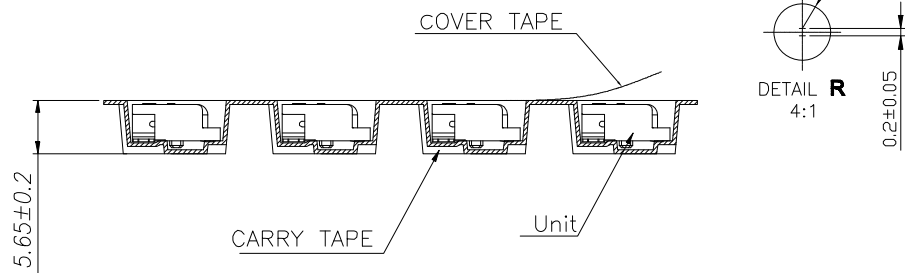
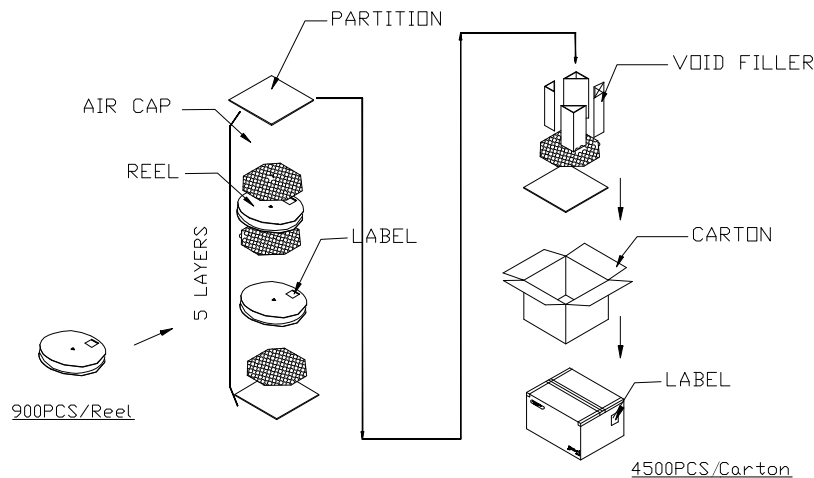
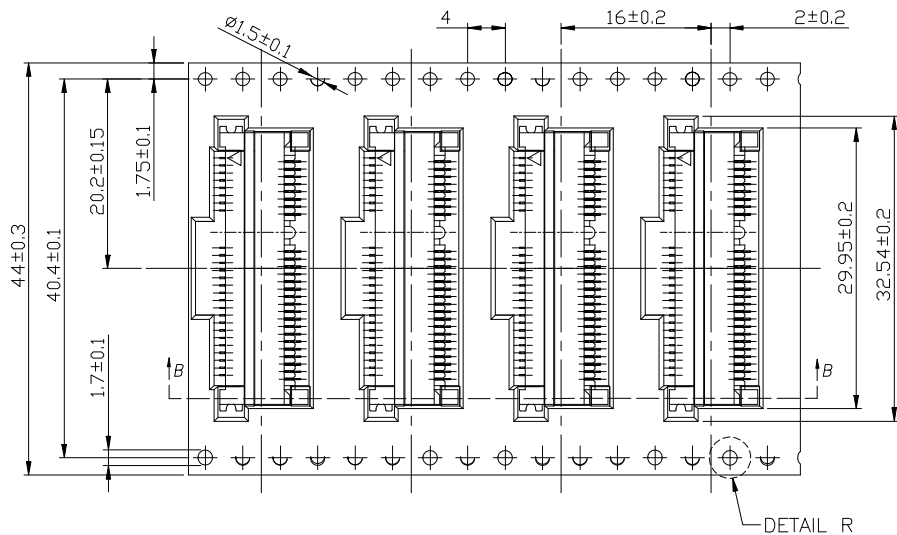

DST-conn Tech. Co., Ltd.

COPYRIGHT RESERVED, PLEASE DO NOT COPY.

PART NAME		Mini PCI EXPRESS 52P 4.0H Conn		DRAWING		Winky		DWG. No.		D130		
PART NO.		D129-WSExx52xxZ		CHECK		Roy		REV.		A		
UNIT : mm	TOLERANCE UNLESS OTHERWISE SPECIFIED		X.X ± 0.30	ANGLE ±2°	APPROVAL		John		DATE		2012/08/01	
			X.XX ± 0.20		SCALE		1:1		PAGE		3 OF 3	
		X.XXX ± 0.10										

F E D C B A