

F

E

D

C

B

A

RoHS Compliant

SYMBOL

REV.

REVISION

APPROVAL

DATE

A

新版圖紙

Winky

2013. 08. 28

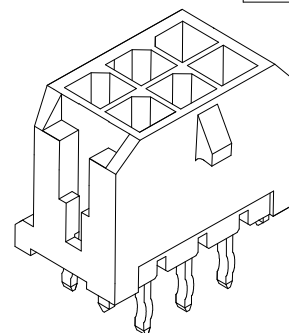
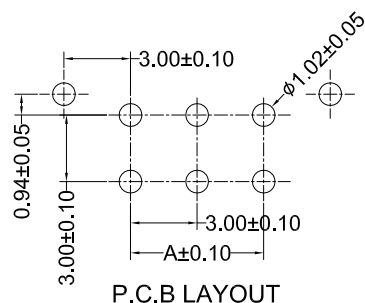
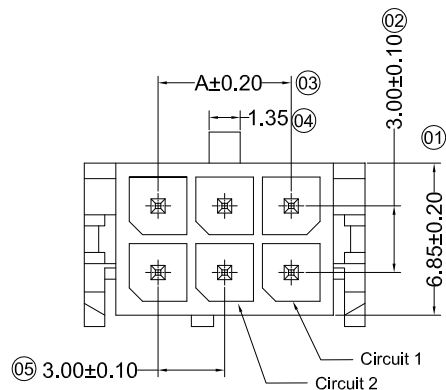

Specifications :

- Voltage rating: 250V AC / DC
- Current rating: 5A AC / DC
- Withstanding voltage: 1000V AC/minute
- Temperature range: $-25^{\circ}\text{C} \sim +85^{\circ}\text{C}$
- Insulation resistance: $\geq 1000\text{M}\Omega$
- Contact resistance: $\leq 10\text{m}\Omega$
- After environmental testing: $\leq 20\text{m}\Omega$

DP03 - V x x xx TL30W

①

②

③

④

⑤

① Series No.

② Welding Board Angle&Way: V: DIP 180°

③ Material: I:PA66 94V-0 G:PBT 94V-0
M:PA46 94V-0④ Planting Category: B:Bright Tin Plating
0:All Gold Flash

⑤ Row No.-Pin No.: xx: 02P~24P

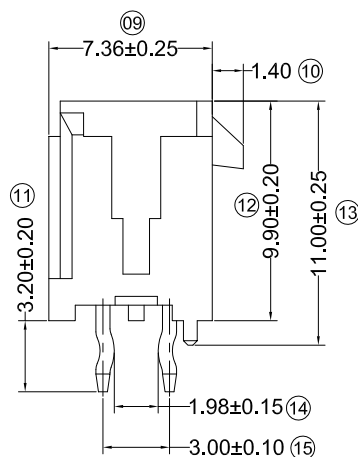
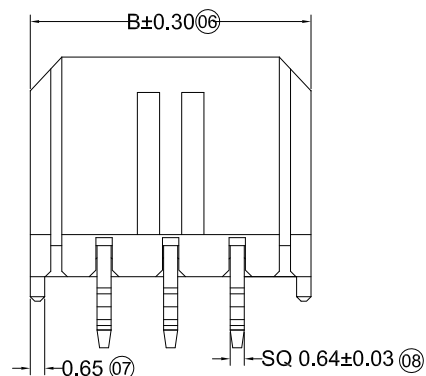

2X1PIN

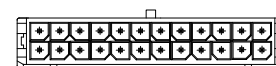

2X12PIN



2X2PIN

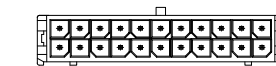

2X11PIN



2X3PIN

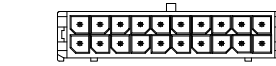

2X10PIN



2X4PIN

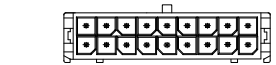

2X9PIN



2X5PIN

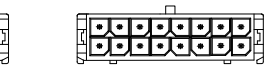

2X8PIN



2X6PIN

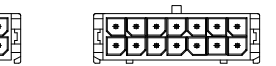

2X7PIN

DP03-VM0xxTL30W	PA46 UL 94V-0	Brass	Gold-Flash	DP02-H
DP03-VIBxxTL30W	PA66 UL 94V-0		Tin-Plated	
DP03-VMBxxTL30W	PA46 UL 94V-0			
DP03-VGBxxTL30W	PBT UL 94V-0			
PART NO	Material	Material(Pin)	Finish(Pin)	Mates With Housing

Poles	Dimensions (mm)		Poles	Dimensions (mm)	
	A	B		A	B
02	---	6.65	14	18.00	24.65
04	3.00	9.65	16	21.00	27.65
06	6.00	12.65	18	24.00	30.65
08	9.00	15.65	20	27.00	33.65
10	12.00	18.65	22	30.00	36.65
12	15.00	21.65	24	33.00	39.65

DST-conn Tech. Co., Ltd.

COPYRIGHT RESERVED, PLEASE DO NOT COPY.

PART NAME	3.00 mm Crimp Style Connectors	DRAWING	Winky	DWG. No.	DP03	
PART NO.	DP03-VxxxxTL30W	CHECK	Roy	REV.	A	
UNIT : mm	TOLERANCE UNLESS OTHERWISE SPECIFIED	X. X ± 0.30 X. XX ± 0.20 X. XXX ± 0.10	APPROVAL	John	DATE	2013. 08. 28
	ANGLE		$\pm 2^{\circ}$	SCALE	1:1	PAGE

F

E

D

C

B

A