

RECOMMENDED PCB LAYOUT
TOP VIEW (TOLERANCE:±0.05)

SPECIFICATIONS:

- ELECTRICAL CHARACTERISTICS:
 - RATING: 24V 3A
 - CONTACT RESISTANCE: 30mΩ MAX.(INITIAL)
 - DIELECTRIC WITHSTANDING VOLTAGE: 500V AC FOR ONE MINUTE
 - INSULATION RESISTANCE: 100MΩ MIN. MEASURED BY 500V DC
- MECHANICAL CHARACTERISTICS:
 - INSERTION FORCE : 0.3~2.0 KGF
 - WITHDRAWAL FORCE : 0.3~2.0 KGF
- LIFE TEST: 5,000 CYCLES MIN.
- FOR REFLOW SOLDERING LEAD-FREE PROCESS.
- * REPRESENT CRITICAL DIMENSIONS.

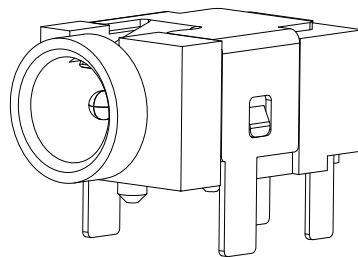
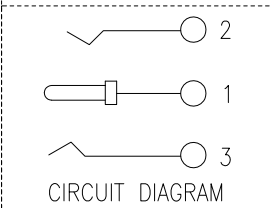
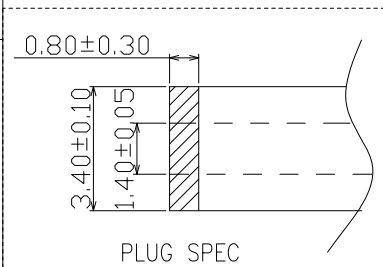
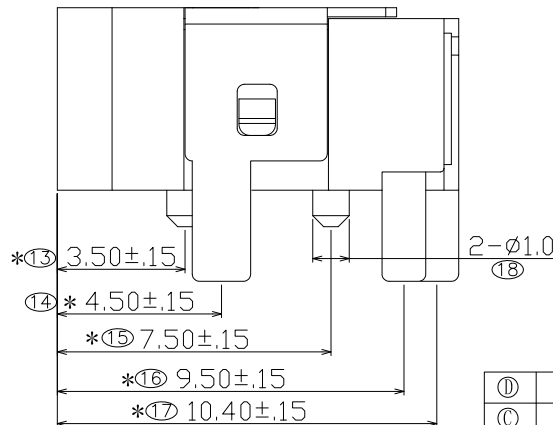
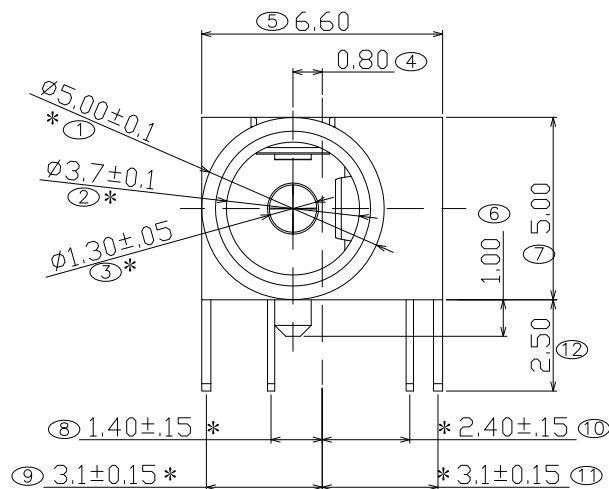

NO.	DESCRIPTION	QTY	MATERIAL	PLATING & COLOR
①	HOUSING	1	PA9T 2330(Black)	Black
③	TERMINAL	1	PHOSPHOR BRONZE t=0.25	Ag-plated
②	TERMINAL	1	PHOSPHOR BRONZE t=0.25	Ag-plated
④	TERMINAL	1	BRASS t=0.20	Ag-plated

UNLESS OTHERWISE SPECIFIED TOLERANCES

DST-conn Tech. Co., Ltd.

DECIMALS:		ANGLES:		DWG NO.		PART NAME:	
DIM	TOL	DIM	TOL	DESIGN:	Winky	DC JACK	
X.	±0.50	X.	±2°	CHECK:	Roy	PART NO.	
X.X	±0.30	X.X	±1°	APPROVED	John	OD060LD130G-D	
X.XX	±0.20	X.XX	—		2010.01.01	REV.	UNIT: SHEET:
X.XXX	±0.10	X.XXX	—		2010.01.01	A	mm 1/1
					2015.03.23		