

F

E

D

C

B

A

RoHS Compliant  
Halogen Free

ZONE	SYMBOL	REVISION	APPROVAL	DATE
	△	0.5 → 1.5 Ø2.8 → Ø2.9 Add R0.2	Winky	17-03-2015

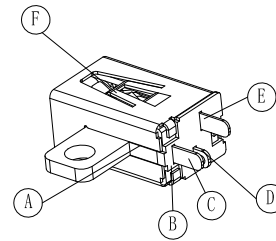
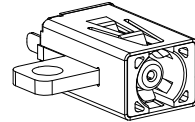
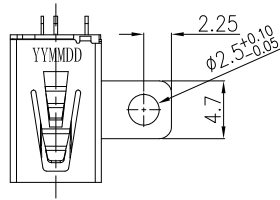

### SPECIFICATIONS

- ELECTRICAL CHARACTERISTICS:
  - 1-1.RATING: DC 20V 5A
  - 1-2.CONTACT RESISTANCE: 30mΩ MAX(INITAL)
  - 1-3.DIELECTRIC WITHSTANDING VOL TAGE: 500V AC FOR ONE MINUTE
  - 1-4.INSULATION RESISTANCE: 100MΩ MIN,MEASURED BY 500V DC
- MECHANICAL CHARACTERISTICS:
  - 2-1.INSERTION FORCE: 2.0KG MAX
  - 2-2.WITHDRAWAL FORCE: 0.8~2.0KG, AFTER LIFE TSET 0.8KG MIN
- LIFE TEST:5,000 CYCLES MIN
- OTHER GENERAL SPEC TO REFER"DC POWER JACK"SPEC
- TO CONFORM TO SINGATRON HAZARDOUS SUBSTANCE FREE SPEC
- GREEN PRODUCT IDENTIFICATION MARK ON JACK: ▲
- GREEN PRODUCT IDENTIFICATION LABEL ON PACKAGING: G.P.PASS
- FOR HAND SOLDERING LEAD FREE PROCESS
- PRINTED DATE CODE" YY MM DD ON TOP OF CONNECTOR

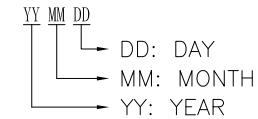
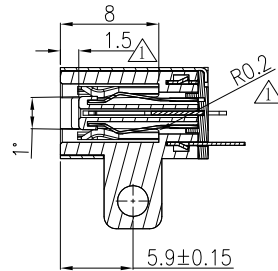
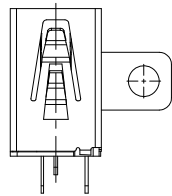
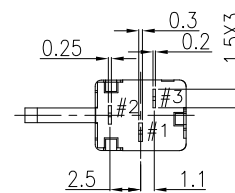
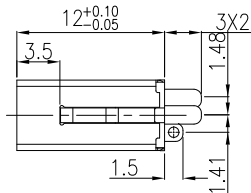
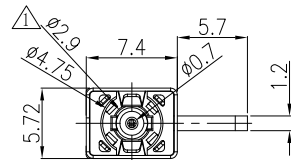

10.Temperature Rise≤30℃

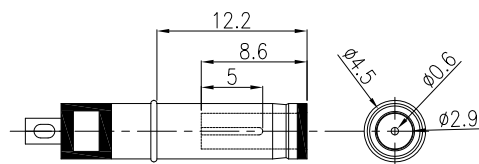

MATING PLUG Ø4.50

### SCHEMATIC

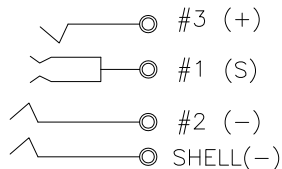

No.	DESCRIPTION	MATERIAL	PLATING
A	BODY	RA230NK	BLACK
B	COVER	RA230NK	BLACK
C	SPRING	C5210	Glod Flash On Contact Area
D	TERMINAL	C5210	Sn 120u"Min On Solder Tail
E	SPRING	C7025	All Over Ni 50u"Min
F	SHELL	SUS	Ni 50u"Min



DST-conn Tech. Co., Ltd.

PART NAME		DC POWER JACK		DESIGN	Winky	TITLE		
PART NO.		ODA19LA060T		DRAWING	Winky	DWG. NO.	D194	
UNIT: mm	MATERIAL	TOLERANCE UNLESS OTHERWISE SPECIFIED:	ANGLE	CHECK	Roy	REV.	B	
	*	0±0.2 0.0±0.1 0.00±0.05	0°±3°	APPROVAL	John	SHEET	1 of 2	

F

E

D

C

B

A

F

E

D

C

B

A

RoHS Compliant  
Halogen Free

ZONE	SYMBOL	REVISION		APPROVAL	DATE
	△	4.9 → 5.9	5.59 → 6.59	Winky	17-03-2015

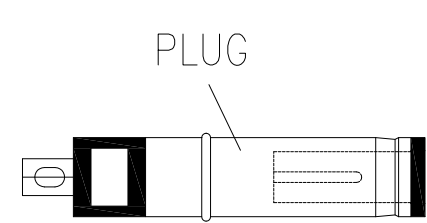

PLUG

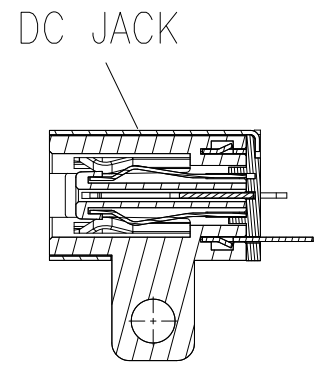

DC JACK

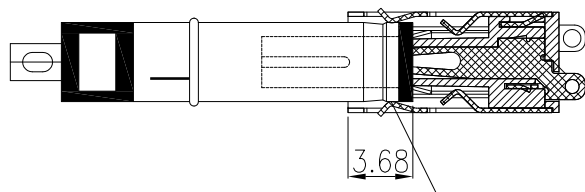

3.68

THE FIRST CONTACT(-)

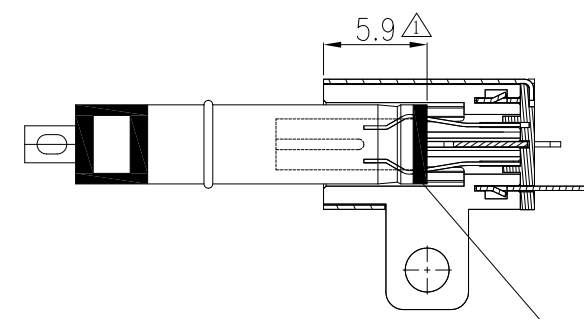

5.9 △

THE SECOND CONTACT(+)

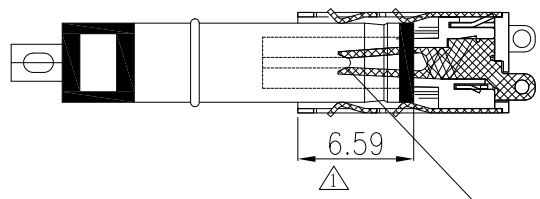

6.59 △

THE THIRD CONTACT

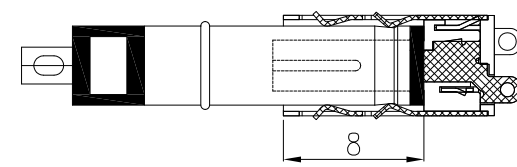

8

FULL INSERT



DST-conn Tech. Co., Ltd.

PART NAME		DC POWER JACK			DESIGN	Winky	TITLE		
PART NO.		ODA19LA060T			DRAWING	Winky	DWG. NO.	D194	
UNIT: mm	MATERIAL	TOLERANCE UNLESS OTHERWISE SPECIFIED:	ANGLE	CHECK	Roy	REV.	B		
	*	0.05x.x 0.00±x.x 0.00±x.x	0°±3°	APPROVAL	John	SHEET	2 of 2		

F

E

D

C

B

A