

REVISION A RoHS Compliant

SYMB	REVISION	DATE	APVD.

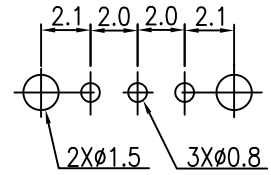

P.C.B LAYOUT
TOP VIEW

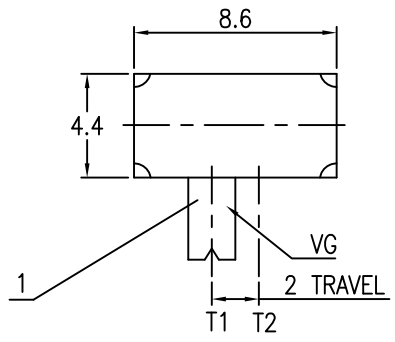
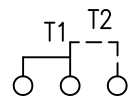
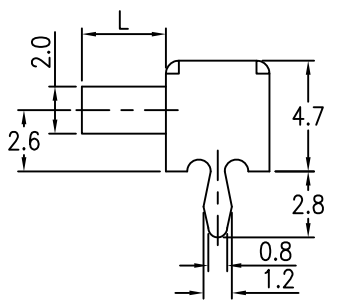
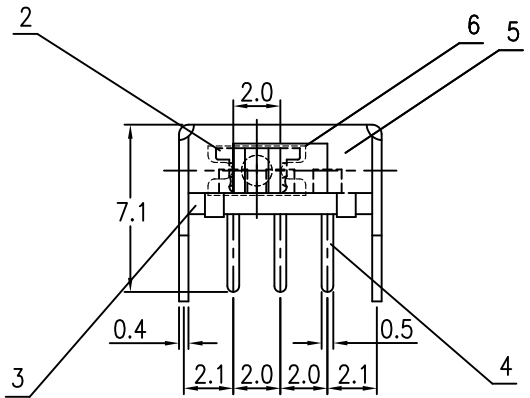

CIRCUIT

L=

TITLE	SLIDE SWITCH	DRAWN	Winky	TOLERANCE OTHERWISE UNLESS SPECIFIED	8					
PART NO.	SWA12DS403G-x	CHECKED	Roy	UP TO 5	±0.2	6	SPRING	C5191	1	NATURAL
DRAW NO.		APPROVED	John	ABOVE 5 ~ 30	±0.3	5	FRAME	SPCC	1	Ni PLATED
				ABOVE 30 ~ 50	±0.4	4	TERMINAL	C2680	3	Ag PLATED
				ABOVE 50	±0.5	3	BASE	PHENOLIC RESIN	1	NATURAL
SCALE: 3:1	UNIT: mm	DATE: 21-10-2014		ANGLE	±3°	2	CONTACT PLATE	C5210	1	Ag PLATED
						1	KNOB	POM	1	BLACK
						NO.	PARTS	MATERIAL	QTY.	FINISHING

DST-conn Tech. Co., Ltd.